



40V 0.9mΩ sTOLL N-Ch Power MOSFET

Features

- Ultra-low ON-resistance, $R_{DS(ON)}$
- Standard Level Threshold, $V_{GS(th)}$
- 100% UIS and R_g Tested
- Pb-free Lead Plating
- Halogen-free and RoHS-compliant
- AEC-Q101 Qualified for Automotive Applications

Product Summary

Parameter	Value	Unit
V_{DS}	40	V
$V_{GS(th),Typ}$	2.8	V
I_D (@ $V_{GS} = 10V$) ⁽²⁾	352	A
$R_{DS(ON),Typ}$ (@ $V_{GS} = 10V$)	0.90	mΩ

PowerJE[®]7x8 Top View

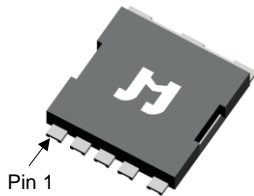

PowerJE[®]7x8 Bottom View

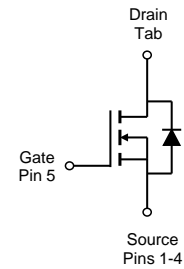
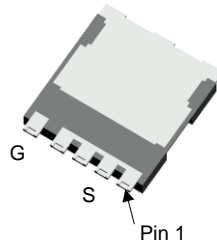

Ordering Information

Device	Package	# of Pins	Marking	MSL	T _J (°C)	Media	Quantity (pcs)
JMSH0401ATSQ-13	PowerJE [®] 7x8 ⁽¹⁾	5	SH0401AQ	1	-55 to 175	13-inch Reel	2000

Note 1: PowerJE[®] is a registered trademark of JieJie Micro., its package outline is compatible to that of s-T0-LeadLess (sTOLL).

Absolute Maximum Ratings (@ T_A = 25°C unless otherwise specified)

Parameter	Symbol	Value	Unit
Drain-to-Source Voltage	V_{DS}	40	V
Gate-to-Source Voltage	V_{GS}	±20	V
Continuous Drain Current	I_D	$T_C = 25^\circ C$ ⁽²⁾	352
		$T_C = 100^\circ C$ ⁽³⁾	238
Pulsed Drain Current ⁽⁴⁾	I_{DM}	931	A
Avalanche Current ⁽⁵⁾	I_{AS}	42	A
Avalanche Energy ⁽⁵⁾	E_{AS}	441	mJ
Power Dissipation ⁽⁶⁾	P_D	$T_C = 25^\circ C$	250
		$T_C = 100^\circ C$	125
Junction & Storage Temperature Range	T _J , T _{STG}	-55 to 175	°C

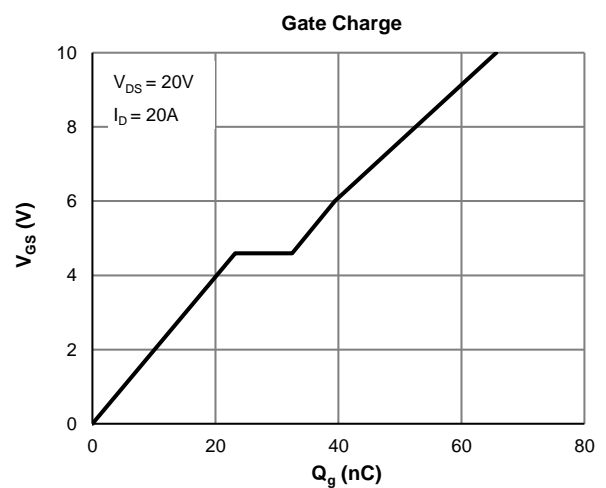
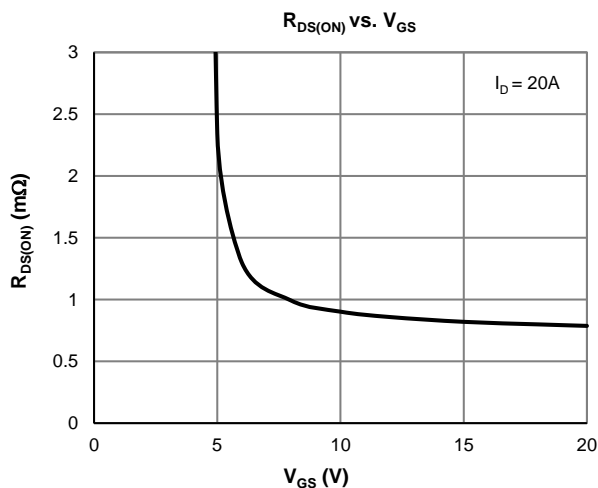

**Electrical Characteristics** (@ $T_J = 25^\circ\text{C}$ unless otherwise specified)

Parameter	Symbol	Conditions	Min.	Typ.	Max.	Unit
STATIC PARAMETERS						
Drain-Source Breakdown Voltage	$V_{(BR)DSS}$	$I_D = 250\mu\text{A}, V_{GS} = 0\text{V}$	40			V
Zero Gate Voltage Drain Current	I_{DSS}	$V_{DS} = 32\text{V}, V_{GS} = 0\text{V}$ $T_J = 55^\circ\text{C}$			1.0 5.0	μA
Gate-Body Leakage Current	I_{GSS}	$V_{DS} = 0\text{V}, V_{GS} = \pm 20\text{V}$			± 100	nA
Gate Threshold Voltage	$V_{GS(th)}$	$V_{DS} = V_{GS}, I_D = 250\mu\text{A}$	2.2	2.8	3.4	V
Static Drain-Source ON-Resistance	$R_{DS(ON)}$	$V_{GS} = 10\text{V}, I_D = 20\text{A}$		0.90	1.1	$\text{m}\Omega$
Forward Transconductance	g_{FS}	$V_{DS} = 5\text{V}, I_D = 20\text{A}$		95		S
Diode Forward Voltage	V_{SD}	$I_S = 1\text{A}, V_{GS} = 0\text{V}$		0.68	1.0	V
Diode Continuous Current	I_S	$T_C = 25^\circ\text{C}$			352	A

DYNAMIC PARAMETERS ⁽⁷⁾

Input Capacitance	C_{iss}	$V_{GS} = 0\text{V}, V_{DS} = 20\text{V}, f = 1\text{MHz}$		5214		pF
Output Capacitance	C_{oss}			3396		pF
Reverse Transfer Capacitance	C_{rss}			46		pF
Gate Resistance	R_g	$V_{GS} = 0\text{V}, V_{DS} = 0\text{V}, f = 1\text{MHz}$		1.9		Ω

SWITCHING PARAMETERS ⁽⁷⁾

Total Gate Charge (@ $V_{GS} = 10\text{V}$)	Q_g	$V_{GS} = 0 \text{ to } 10\text{V}$ $V_{DS} = 20\text{V}, I_D = 20\text{A}$		66		nC
Total Gate Charge (@ $V_{GS} = 6.0\text{V}$)	Q_g			40		nC
Gate Source Charge	Q_{gs}			23		nC
Gate Drain Charge	Q_{gd}			9.3		nC
Turn-On DelayTime	$t_{D(on)}$	$V_{GS} = 10\text{V}, V_{DS} = 20\text{V}$ $R_L = 1.0\Omega, R_{GEN} = 3\Omega$		20		ns
Turn-On Rise Time	t_r			17.2		ns
Turn-Off DelayTime	$t_{D(off)}$			43		ns
Turn-Off Fall Time	t_f			16.1		ns
Body Diode Reverse Recovery Time	t_{rr}		$I_F = 20\text{A}, dI_F/dt = 100\text{A}/\mu\text{s}$		68	
Body Diode Reverse Recovery Charge	Q_{rr}	$I_F = 20\text{A}, dI_F/dt = 100\text{A}/\mu\text{s}$		78		nC

Thermal Performance

Parameter	Symbol	Typ.	Max.	Unit
Thermal Resistance, Junction-to-Ambient	$R_{\theta JA}$	42	50	$^\circ\text{C}/\text{W}$
Thermal Resistance, Junction-to-Case	$R_{\theta JC}$	0.60	0.70	$^\circ\text{C}/\text{W}$

Notes:

- Continuous current rating is limited by the package used; and the chip current is able to carry 330A while $R_{\theta JC} \leq 0.70^\circ\text{C}/\text{W}$.
- This value is verified by characterization hence it is not included in the production test.
- This single-pulse measurement was taken under $T_{J_Max} = 175^\circ\text{C}$.
- This single-pulse measurement was taken under the following condition [$L = 500\mu\text{H}, V_{GS} = 10\text{V}, V_{DD} = 20\text{V}$] while its value is limited by $T_{J_Max} = 175^\circ\text{C}$.
- The power dissipation P_D is based on $T_{J_Max} = 175^\circ\text{C}$.
- This value is guaranteed by design hence it is not included in the production test.

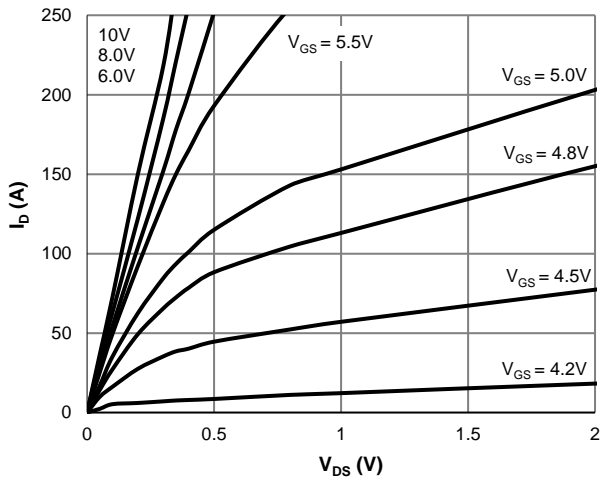
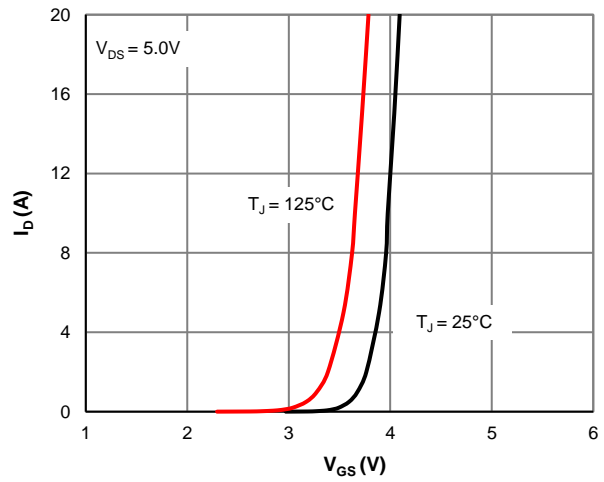
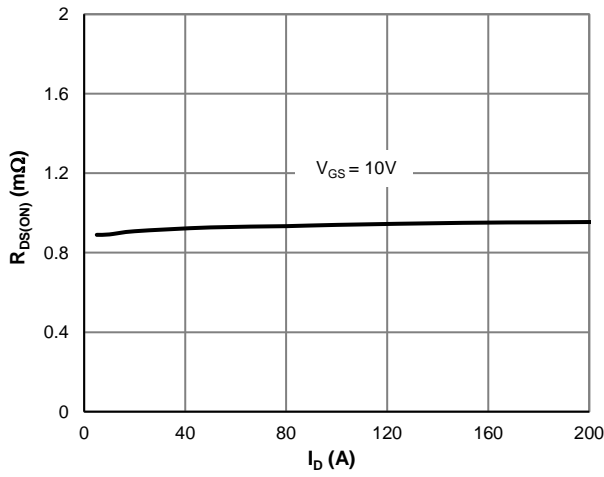
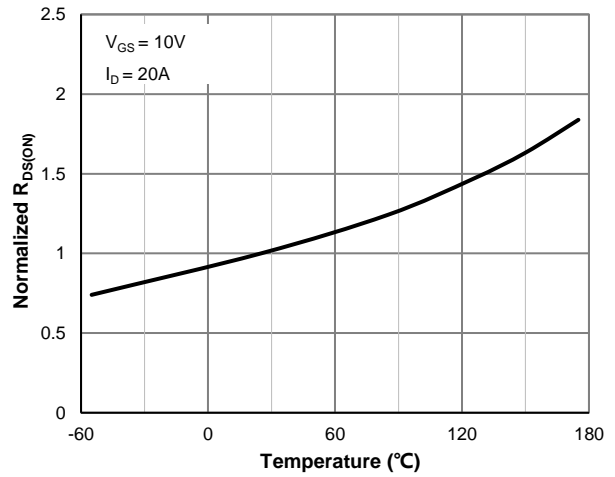
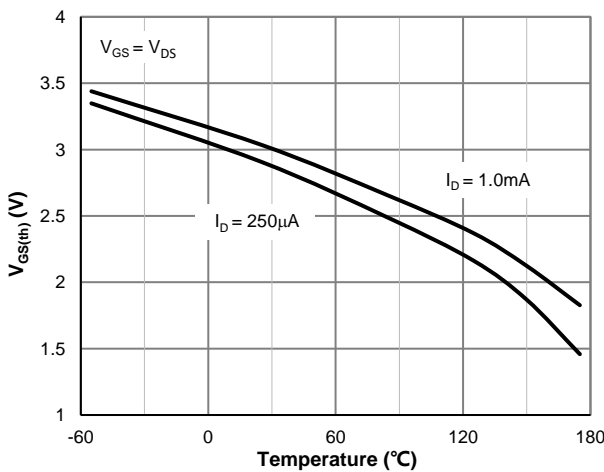
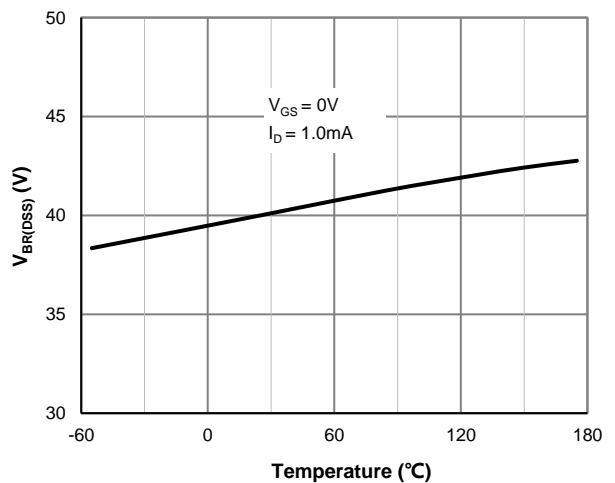
Typical Electrical & Thermal Characteristics

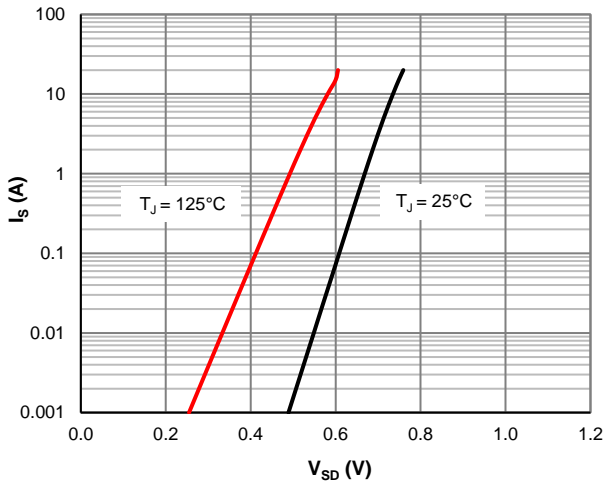
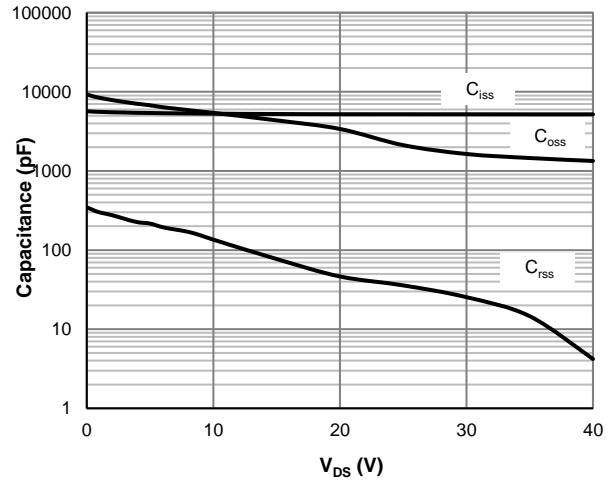
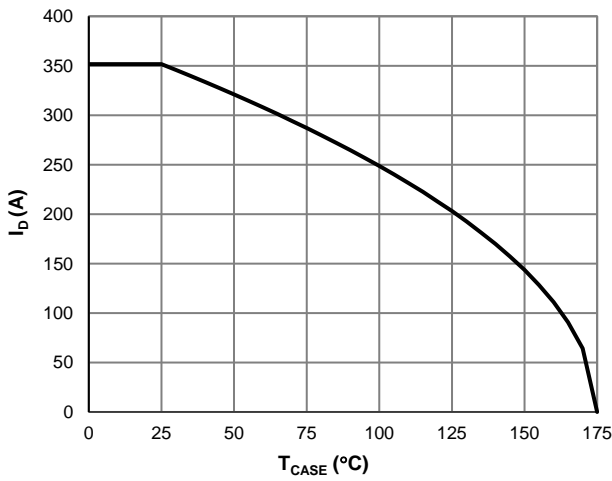
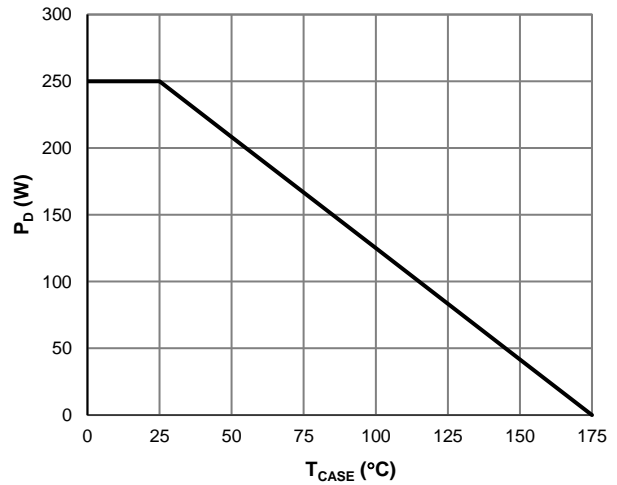
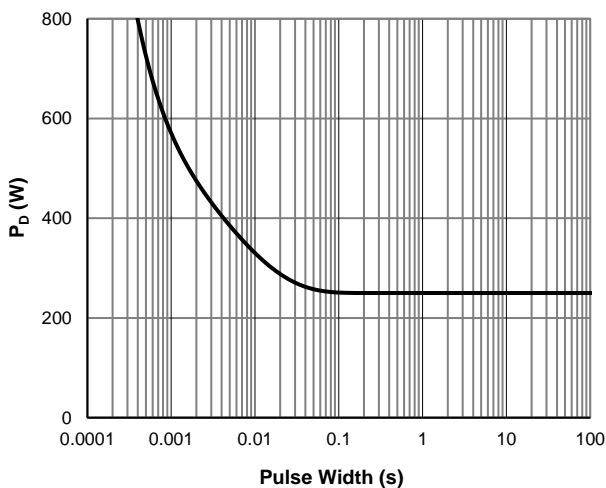
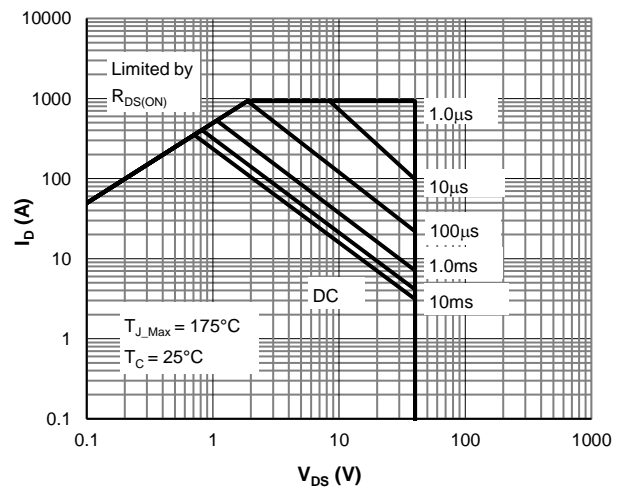
Figure 1: Saturation Characteristics

Figure 2: Transfer Characteristics

Figure 3: $R_{DS(ON)}$ vs. Drain Current

Figure 4: $R_{DS(ON)}$ vs. Junction Temperature

Figure 5: $V_{GS(th)}$ vs. Junction Temperature

Figure 6: $V_{BR(DSS)}$ vs. Junction Temperature

Typical Electrical & Thermal Characteristics

Figure 7: Body-Diode Characteristics

Figure 8: Capacitance Characteristics

Figure 9: Current De-rating

Figure 10: Power De-rating

Figure 11: Single Pulse Power Rating, Junction-to-Case

Figure 12: Maximum Safe Operating Area



Typical Electrical & Thermal Characteristics

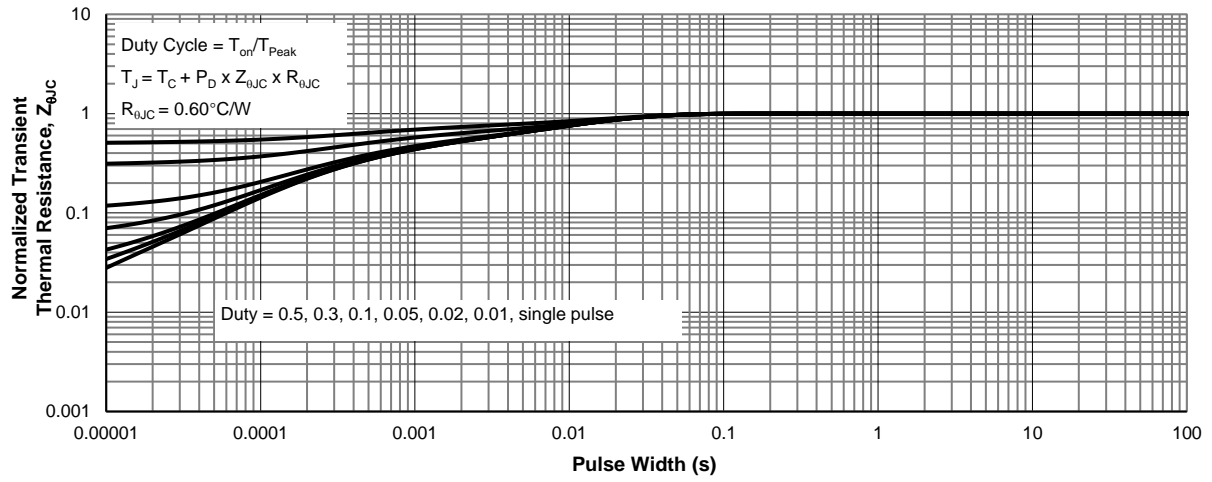
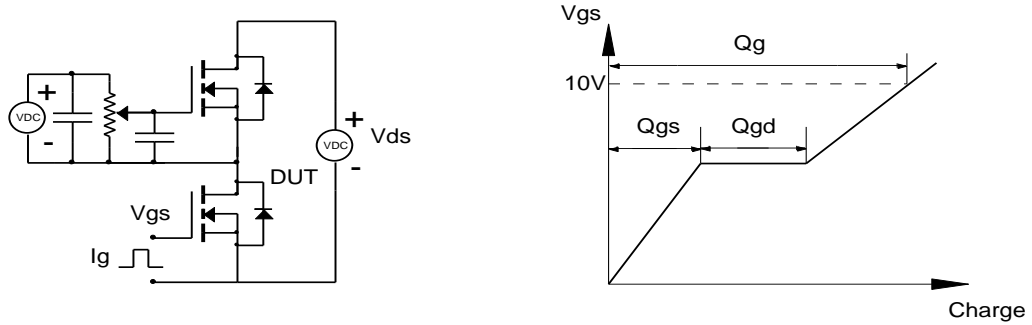
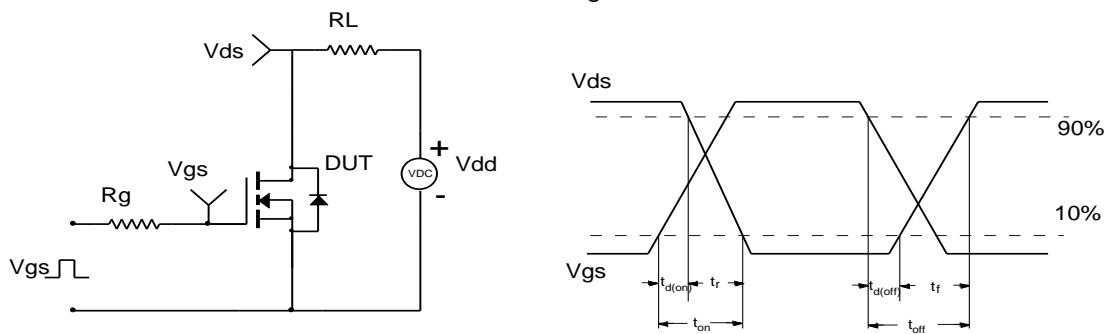

Figure 13: Normalized Maximum Transient Thermal Impedance

Gate Charge Test Circuit & Waveform



Resistive Switching Test Circuit & Waveforms



Unclamped Inductive Switching (UIS) Test Circuit & Waveforms

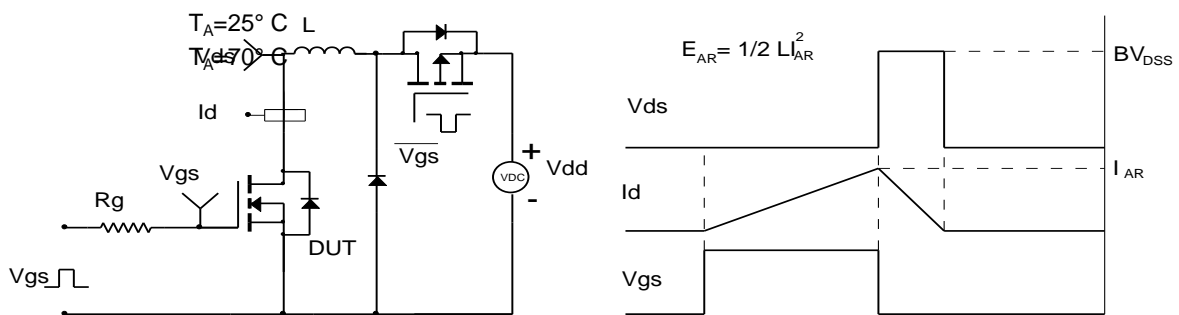

Diode Recovery Test Circuit & Waveforms

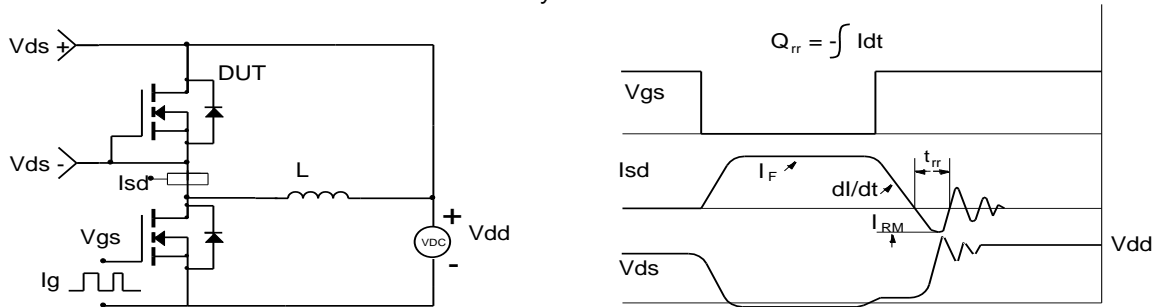

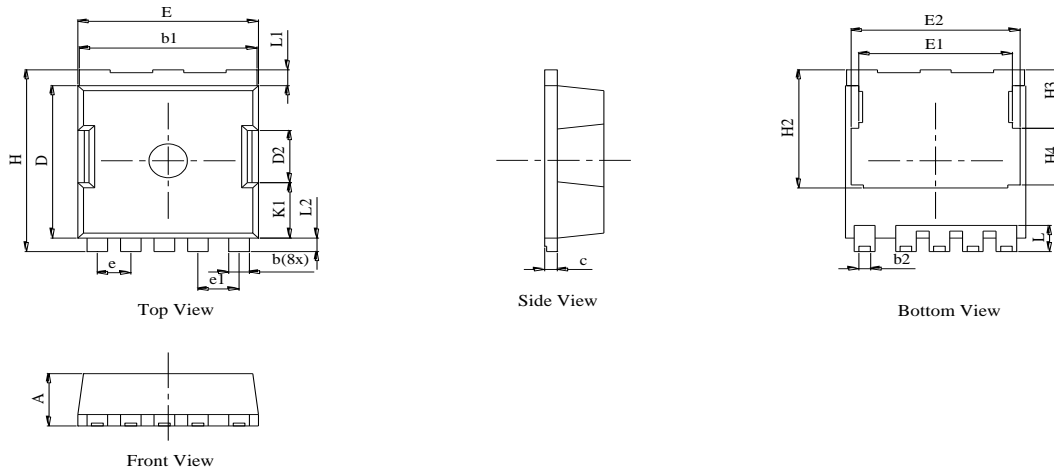
PowerJE[®]7x8 Package Information
Package Outlines

NOTES:

1. Dimension and tolerance per ASME Y14.5M, 1994.
2. All dimensions in millimeter.
3. Dimensions do not include burrs or mold flash.

DIM.	MILLIMETER		
	MIN.	NOM.	MAX.
A	2.20	2.30	2.40
b	0.70	0.80	0.90
b1	6.80	6.90	7.00
b2	0.40	0.45	0.50
c	0.40	0.50	0.60
D	6.50	6.70	6.90
D2	2.30 (REF)		
E	6.80	7.00	7.20
E1	5.96 (REF)		
E2	6.56 (REF)		
e	1.30 (BSC)		
e1	1.60 (BSC)		
H	7.80	8.00	8.20
H2	5.20 (REF)		
H3	2.57 (REF)		
H4	2.50 (REF)		
K1	2.43 (REF)		
L	1.05	1.15	1.25
L1	0.70		
L2	0.60		

Recommended Soldering Footprint
