



## 40V 5.5mΩ Dual N-Ch Power MOSFET

### Features

- Ultra-low ON-resistance,  $R_{DS(ON)}$
- Low Gate Charge,  $Q_g$
- 100% UIS and  $R_g$  Tested
- Pb-free Lead Plating
- Halogen-free and RoHS-compliant
- AEC-Q101 Qualified for Automotive Applications

### Product Summary

| Parameter                                | Value | Unit |
|--|-------|------|
| $V_{DS}$                                 | 40    | V    |
| $V_{GS(th)}_{Typ}$                       | 1.6   | V    |
| $I_D$ (@ $V_{GS} = 10V$ ) <sup>(1)</sup> | 49    | A    |
| $R_{DS(ON)}_{Typ}$ (@ $V_{GS} = 10V$ )   | 5.5   | mΩ   |
| $R_{DS(ON)}_{Typ}$ (@ $V_{GS} = 4.5V$ )  | 7.0   | mΩ   |

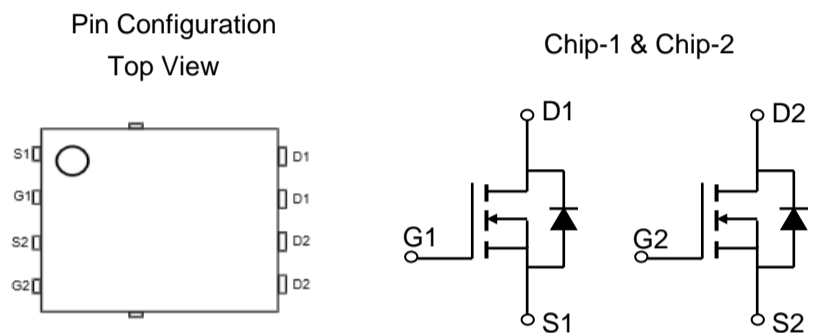
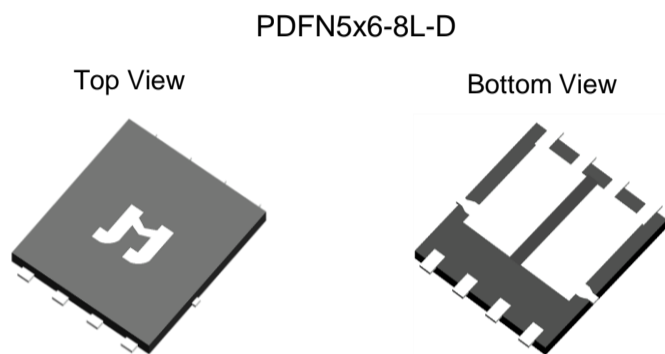

### Ordering Information

| Device          | Package      | # of Pins | Marking | MSL | $T_J$ (°C) | Media        | Quantity (pcs) |
|-----------------|--------------|-----------|---------|-----|------------|--------------|----------------|
| JMSL0406AGDQ-13 | PDFN5x6-8L-D | 8         | L0406AD | 1   | -55 to 175 | 13-inch Reel | 5000           |

### Absolute Maximum Ratings (@ $T_A = 25^\circ C$ unless otherwise specified)

| Parameter                               | Symbol         | Value               | Unit |
|---|----------------|---------------------|------|
| Drain-to-Source Voltage                 | $V_{DS}$       | 40                  | V    |
| Gate-to-Source Voltage                  | $V_{GS}$       | ±20                 | V    |
| Continuous Drain Current <sup>(1)</sup> | $I_D$          | $T_C = 25^\circ C$  | 49   |
|   |                | $T_C = 100^\circ C$ | 35   |
| Pulsed Drain Current <sup>(2)</sup>     | $I_{DM}$       | 166                 | A    |
| Avalanche Current <sup>(3)</sup>        | $I_{AS}$       | 27                  | A    |
| Avalanche Energy <sup>(3)</sup>         | $E_{AS}$       | 36                  | mJ   |
| Power Dissipation <sup>(4)</sup>        | $P_D$          | $T_C = 25^\circ C$  | 29   |
|   |                | $T_C = 100^\circ C$ | 14.7 |
| Junction & Storage Temperature Range    | $T_J, T_{STG}$ | -55 to 175          | °C   |

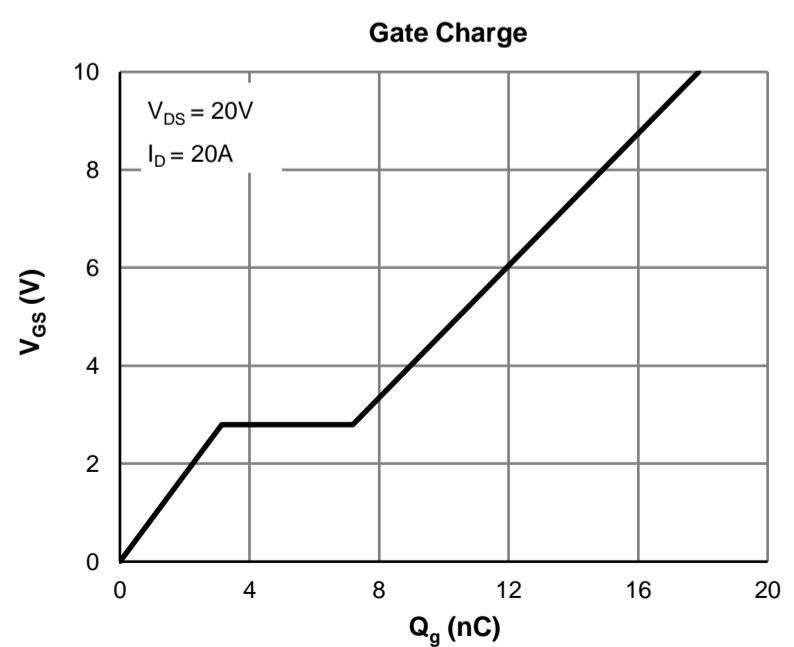
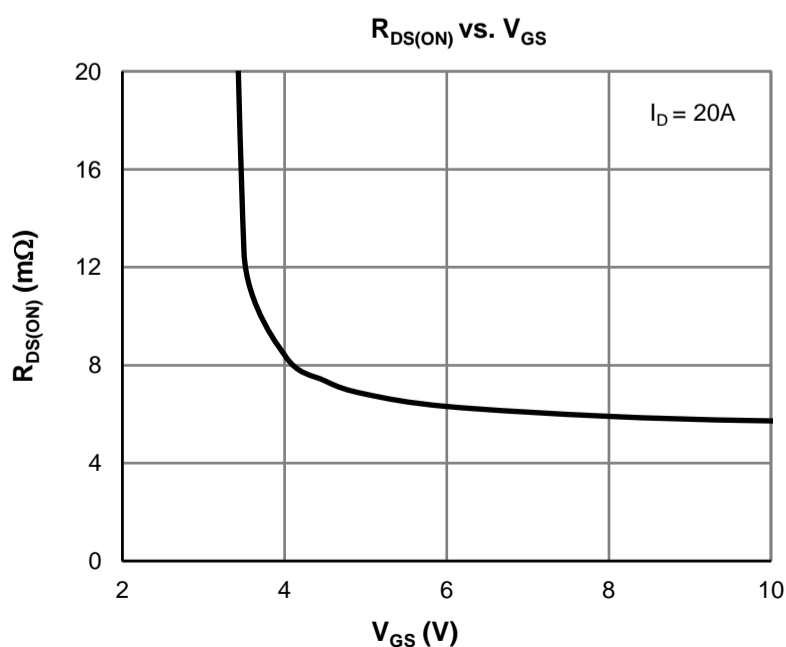



**Electrical Characteristics** (@  $T_J = 25^\circ\text{C}$  unless otherwise specified)

| Parameter                         | Symbol        | Conditions  | Min. | Typ. | Max.      | Unit             |
|-----------------------------------|---------------|---|------|------|-----------|------------------|
| <b>STATIC PARAMETERS</b>          |               |   |      |      |           |                  |
| Drain-Source Breakdown Voltage    | $V_{(BR)DSS}$ | $I_D = 250\mu\text{A}, V_{GS} = 0\text{V}$  | 40   |      |           | V                |
| Zero Gate Voltage Drain Current   | $I_{DSS}$     | $V_{DS} = 32\text{V}, V_{GS} = 0\text{V}$   |      |      | 1.0       | $\mu\text{A}$    |
|                                   |               |   |      |      | 5.0       |                  |
| Gate-Body Leakage Current         | $I_{GSS}$     | $V_{DS} = 0\text{V}, V_{GS} = \pm 20\text{V}$                                       |      |      | $\pm 100$ | nA               |
| Gate Threshold Voltage            | $V_{GS(th)}$  | $V_{DS} = V_{GS}, I_D = 250\mu\text{A}$   | 1.2  | 1.6  | 2.5       | V                |
| Static Drain-Source ON-Resistance | $R_{DS(on)}$  | $V_{GS} = 10\text{V}, I_D = 20\text{A}$<br>$V_{GS} = 4.5\text{V}, I_D = 15\text{A}$ |      | 5.5  | 6.9       | $\text{m}\Omega$ |
|                                   |               |   |      | 7.0  | 9.5       | $\text{m}\Omega$ |
| Forward Transconductance          | $g_{FS}$      | $V_{DS} = 5\text{V}, I_D = 20\text{A}$  |      | 95   |           | S                |
| Diode Forward Voltage             | $V_{SD}$      | $I_S = 1\text{A}, V_{GS} = 0\text{V}$   |      | 0.71 | 1.0       | V                |
| Diode Continuous Current          | $I_S$         | $T_C = 25^\circ\text{C}$  |      |      | 49        | A                |

**DYNAMIC PARAMETERS** <sup>(5)</sup>

|                              |           |  |  |      |  |          |
|------------------------------|-----------|--|--|------|--|----------|
| Input Capacitance            | $C_{iss}$ | $V_{GS} = 0\text{V}, V_{DS} = 20\text{V}, f = 1\text{MHz}$ |  | 1227 |  | pF       |
| Output Capacitance           | $C_{oss}$ |  |  | 526  |  | pF       |
| Reverse Transfer Capacitance | $C_{rss}$ |  |  | 55   |  | pF       |
| Gate Resistance              | $R_g$     | $V_{GS} = 0\text{V}, V_{DS} = 0\text{V}, f = 1\text{MHz}$  |  | 2.7  |  | $\Omega$ |

**SWITCHING PARAMETERS** <sup>(5)</sup>

|   |              |  |  |      |  |    |
|---|--------------|--|--|------|--|----|
| Total Gate Charge (@ $V_{GS} = 10\text{V}$ )  | $Q_g$        | $V_{GS} = 0 \text{ to } 10\text{V}$<br>$V_{DS} = 20\text{V}, I_D = 20\text{A}$     |  | 17.9 |  | nC |
| Total Gate Charge (@ $V_{GS} = 4.5\text{V}$ ) | $Q_g$        |  |  | 9.7  |  | nC |
| Gate Source Charge                            | $Q_{gs}$     |  |  | 3.2  |  | nC |
| Gate Drain Charge                             | $Q_{gd}$     |  |  | 4.0  |  | nC |
| Turn-On DelayTime                             | $t_{D(on)}$  |  |  | 5.0  |  | ns |
| Turn-On Rise Time                             | $t_r$        | $V_{GS} = 10\text{V}, V_{DS} = 20\text{V}$<br>$R_L = 1.0\Omega, R_{GEN} = 6\Omega$ |  | 7.0  |  | ns |
| Turn-Off DelayTime                            | $t_{D(off)}$ |  |  | 23   |  | ns |
| Turn-Off Fall Time                            | $t_f$        |  |  | 14.8 |  | ns |
| Body Diode Reverse Recovery Time              | $t_{rr}$     | $I_F = 20\text{A}, dI_F/dt = 100\text{A}/\mu\text{s}$                              |  | 26   |  | ns |
| Body Diode Reverse Recovery Charge            | $Q_{rr}$     | $I_F = 20\text{A}, dI_F/dt = 100\text{A}/\mu\text{s}$                              |  | 14.0 |  | nC |

**Thermal Performance**

| Parameter                               | Symbol          | Typ. | Max. | Unit                      |
|---|-----------------|------|------|---------------------------|
| Thermal Resistance, Junction-to-Ambient | $R_{\theta JA}$ | 65   | 78   | $^\circ\text{C}/\text{W}$ |
| Thermal Resistance, Junction-to-Case    | $R_{\theta JC}$ | 5.1  | 6.2  | $^\circ\text{C}/\text{W}$ |

**Notes:**

1. Computed continuous current assumes the condition of  $T_{J\_Max}$  while the actual continuous current depends on the thermal & electro-mechanical application board design.
2. This single-pulse measurement was taken under  $T_{J\_Max} = 175^\circ\text{C}$ .
3. This single-pulse measurement was taken under the following condition [ $L = 100\mu\text{H}, V_{GS} = 10\text{V}, V_{DD} = 20\text{V}$ ] while its value is limited by  $T_{J\_Max} = 175^\circ\text{C}$ .
4. The power dissipation  $P_D$  is based on  $T_{J\_Max} = 175^\circ\text{C}$ .
5. This value is guaranteed by design hence it is not included in the production test.

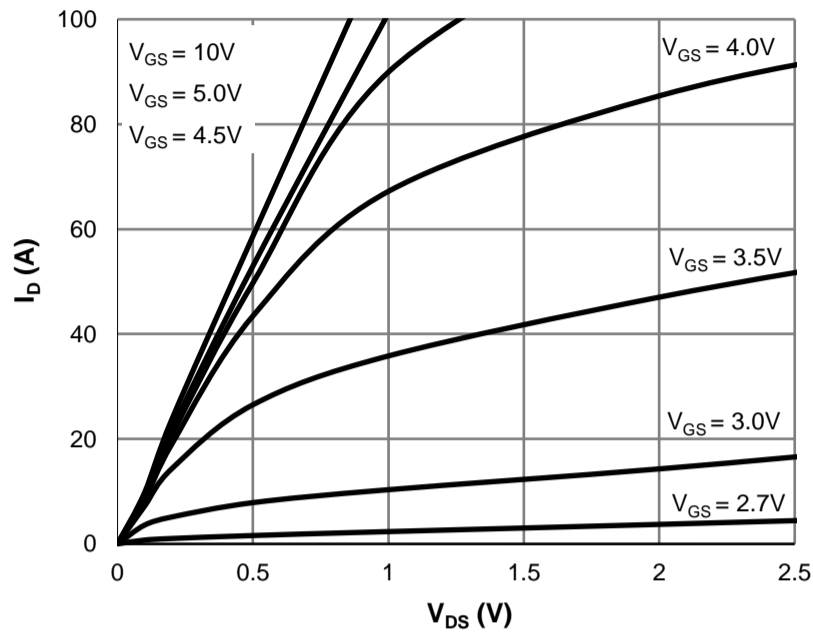
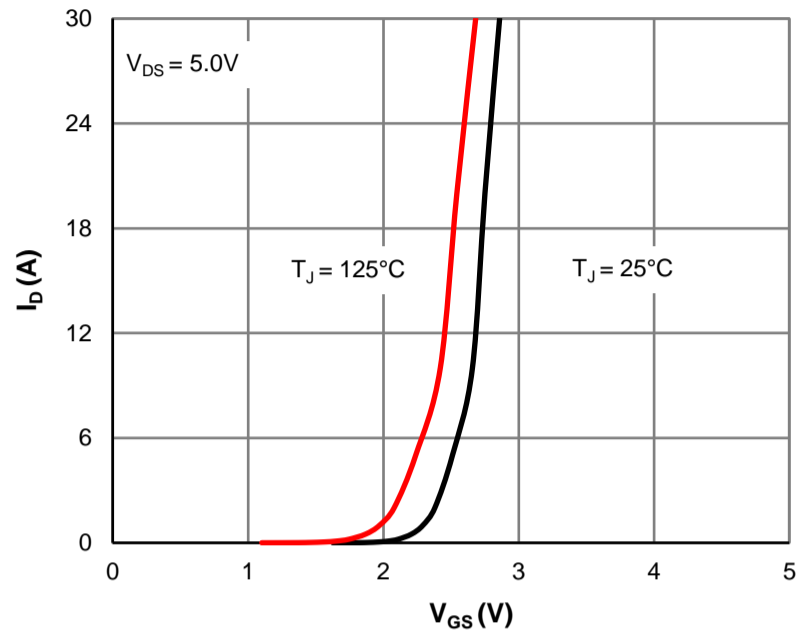
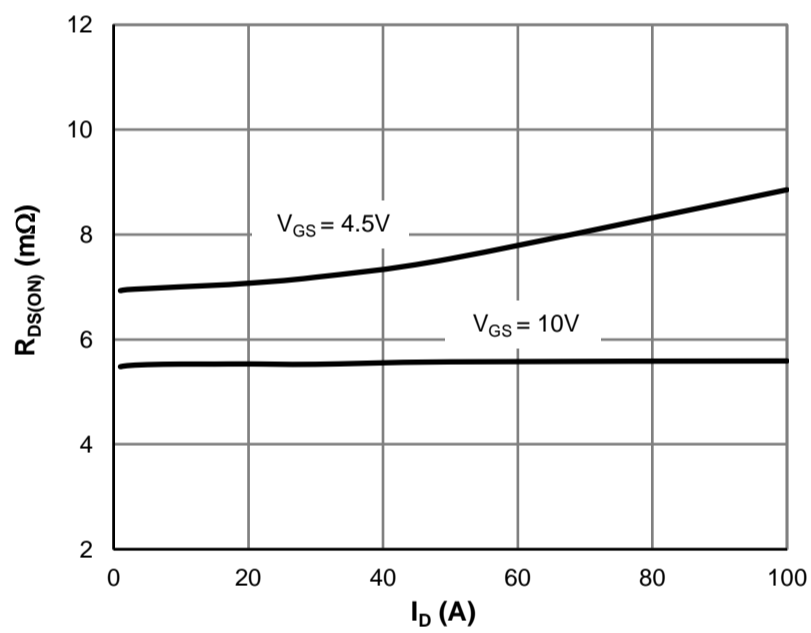
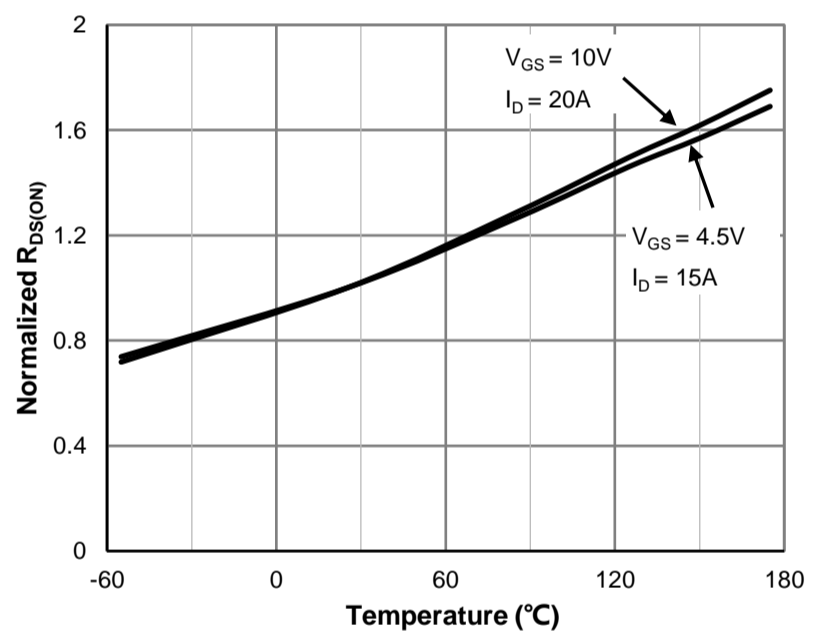
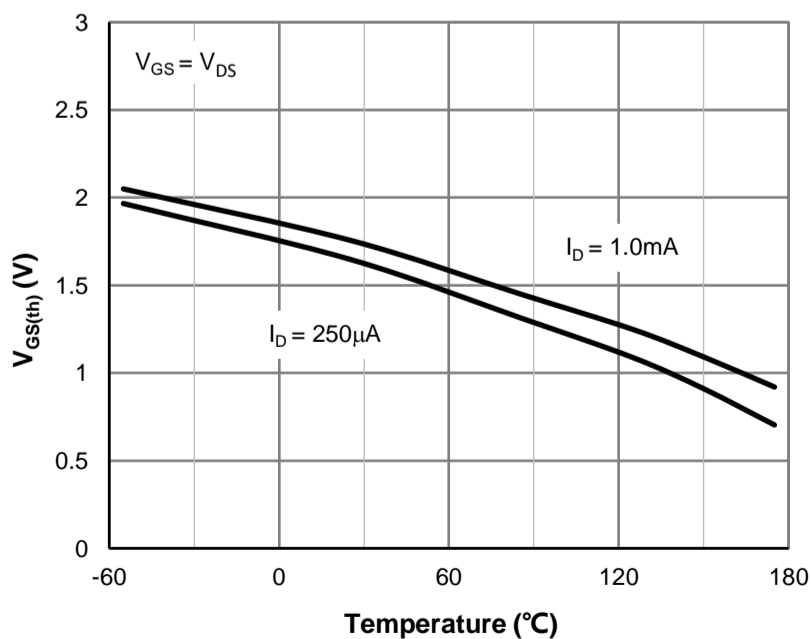
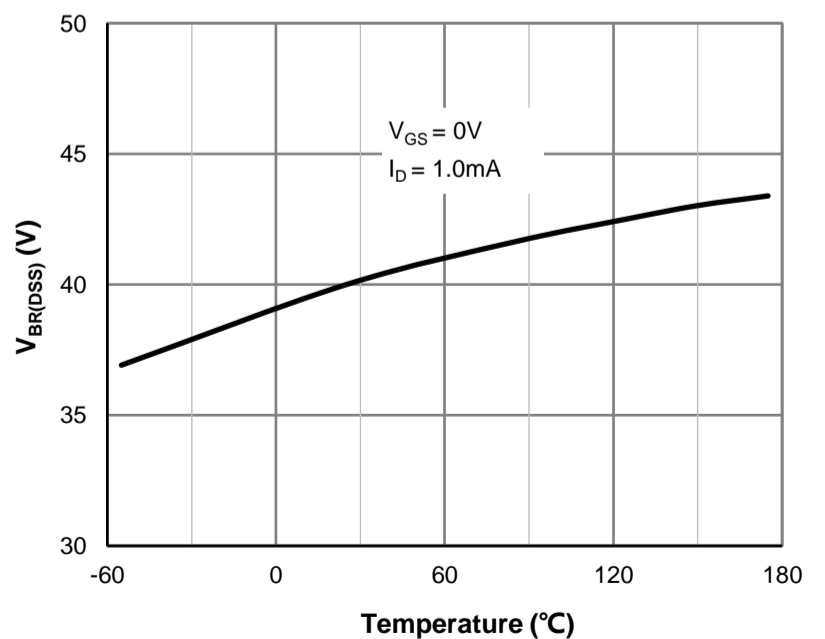
**Typical Electrical & Thermal Characteristics**

**Figure 1: Saturation Characteristics**

**Figure 2: Transfer Characteristics**

**Figure 3:  $R_{DS(ON)}$  vs. Drain Current**

**Figure 4:  $R_{DS(ON)}$  vs. Junction Temperature**

**Figure 5:  $V_{GS(th)}$  vs. Junction Temperature**

**Figure 6:  $V_{BR(DSS)}$  vs. Junction Temperature**

Typical Electrical & Thermal Characteristics

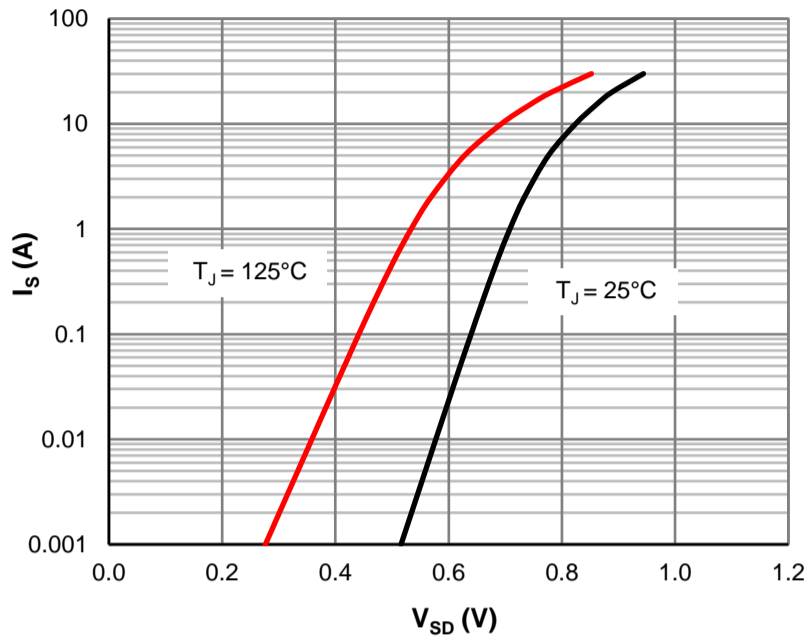

Figure 7: Body-Diode Characteristics

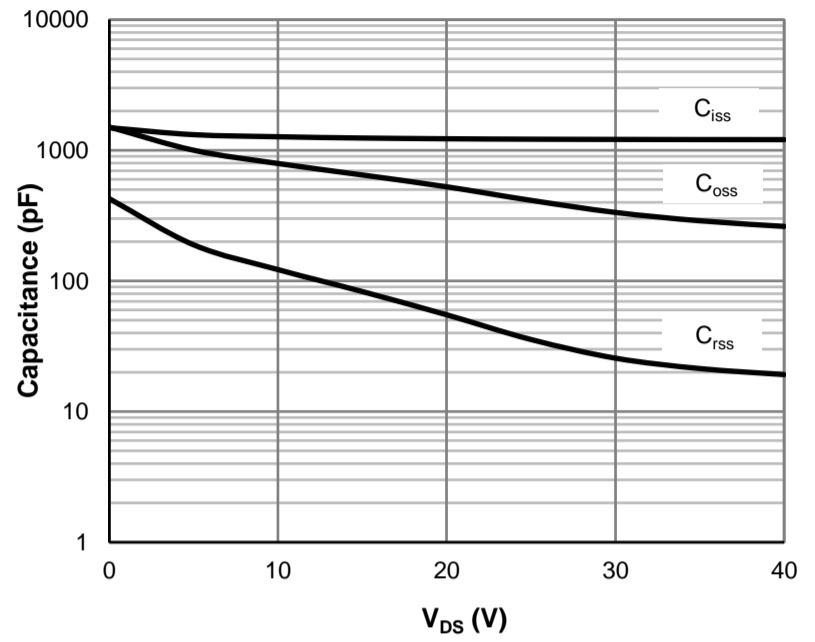

Figure 8: Capacitance Characteristics

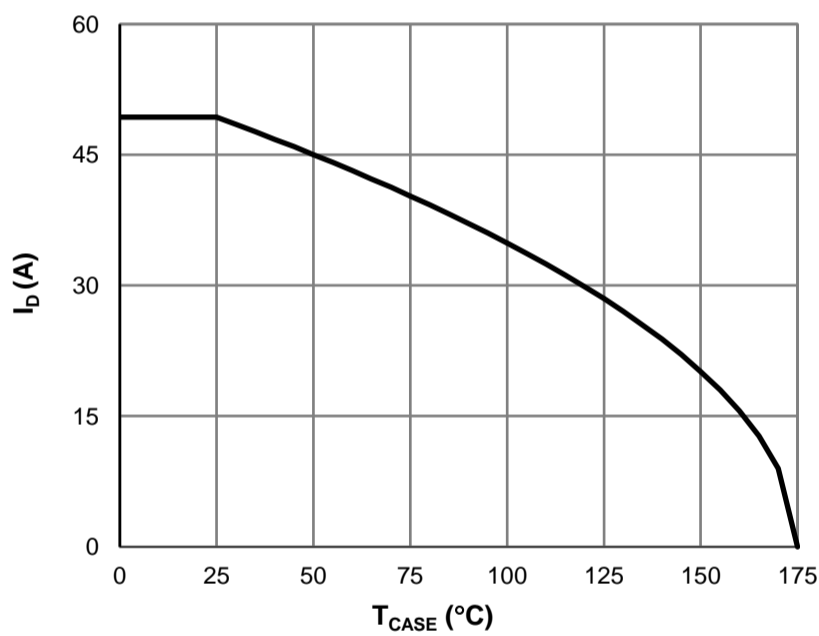

Figure 9: Current De-rating

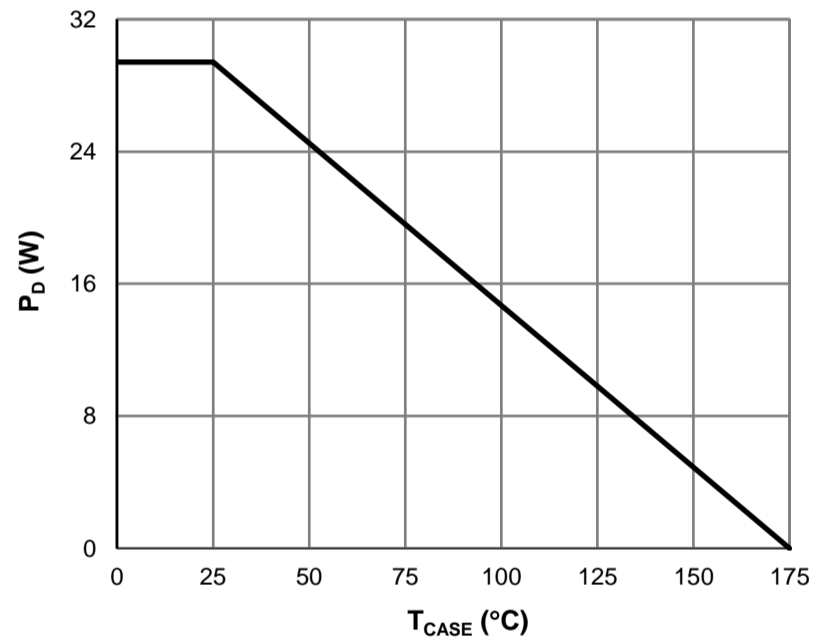

Figure 10: Power De-rating

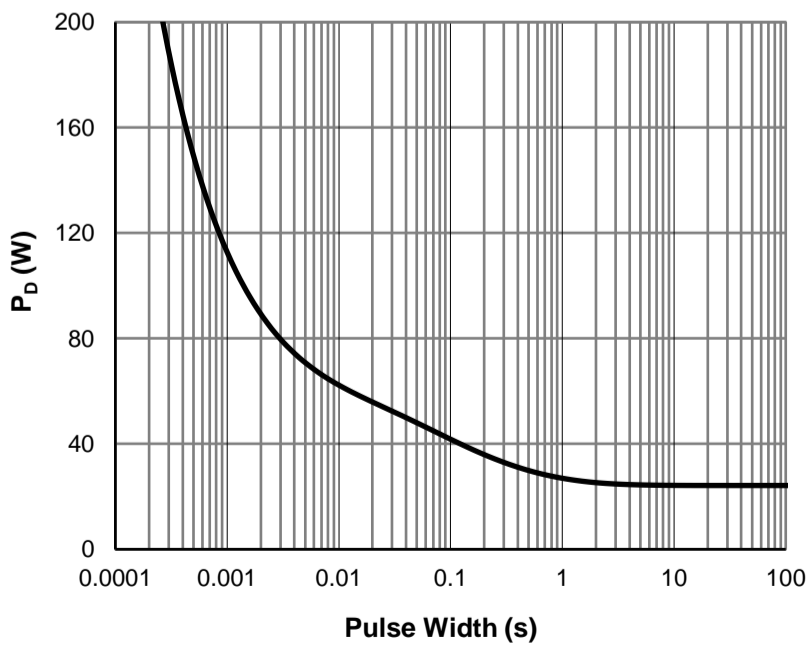

Figure 11: Single Pulse Power Rating, Junction-to-Case

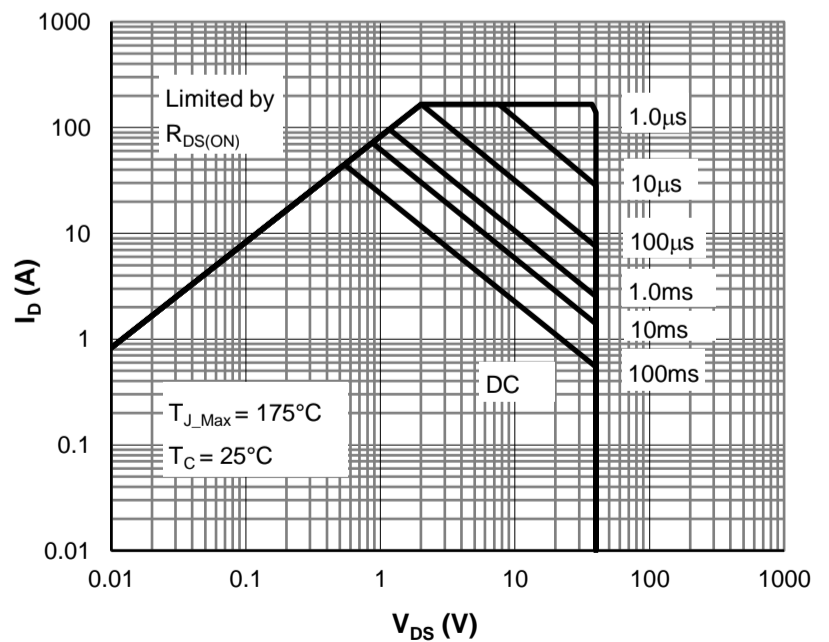

Figure 12: Maximum Safe Operating Area

Typical Electrical & Thermal Characteristics

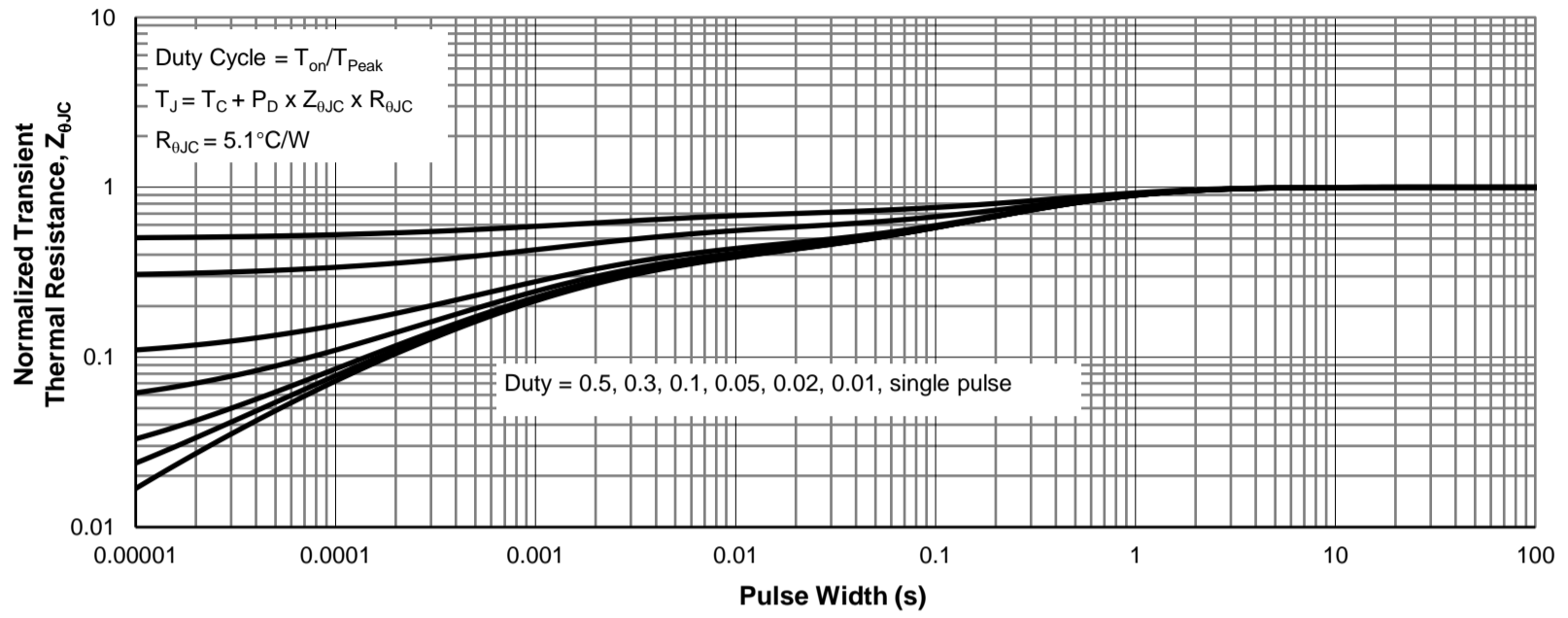
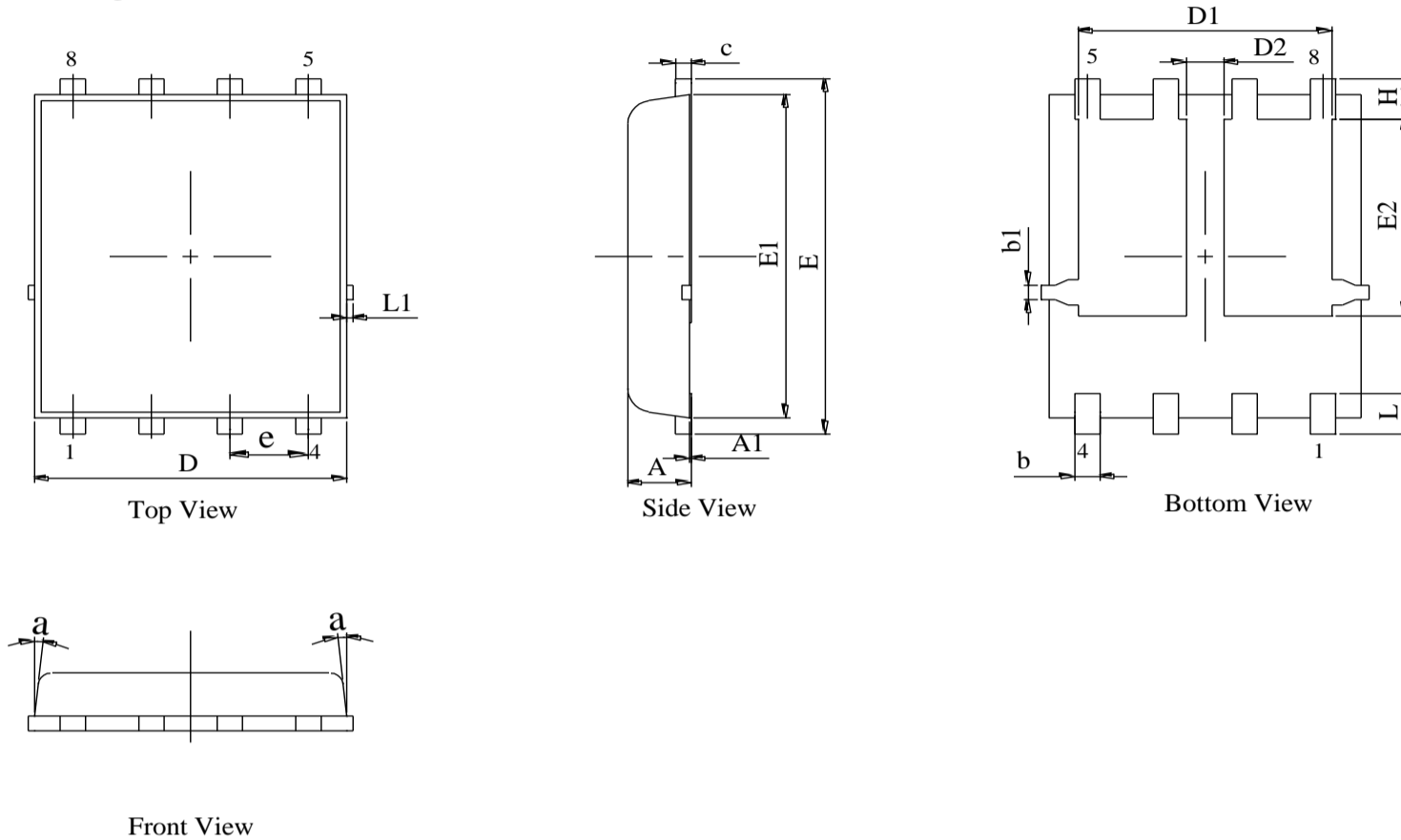

Figure 13: Normalized Maximum Transient Thermal Impedance

PDFN5x6-8L-D Package Information

Package Outline



Front View

NOTES:

1. DIMENSIONING AND TOLERANCING PER ASME Y14.5M, 1994.
2. ALL DIMENSIONS IN MILLIMETER (ANGLE IN DEGREE).
3. DIMENSIONS D1 AND E1 DO NOT INCLUDE MOLD FLASH PROTRUSIONS OR GATE BURRS.

| DIM. | MILLIMETER |      |       |
|------|------------|------|-------|
|      | MIN.       | NOM. | MAX.  |
| A    | 0.90       | 1.00 | 1.10  |
| A1   | 0.00       | -    | 0.10  |
| b    | 0.31       | 0.41 | 0.51  |
| b1   | 0.15       | 0.25 | 0.35  |
| c    | 0.23       | -    | 0.33  |
| D    | 4.95       | 5.05 | 5.15  |
| D1   | 4.00       | 4.10 | 4.20  |
| D2   | 0.50       | 0.60 | 0.70  |
| E    | 6.05       | 6.15 | 6.25  |
| E1   | 5.50       | 5.60 | 5.70  |
| E2   | 3.31       | 3.41 | 3.51  |
| e    | 1.27BSC    |      |       |
| H    | 0.60       | 0.70 | 0.80  |
| L    | 0.50       | 0.70 | 0.80  |
| L1   | -          | -    | 0.125 |
| a    | -          | -    | 12°   |

Recommended Soldering Footprint

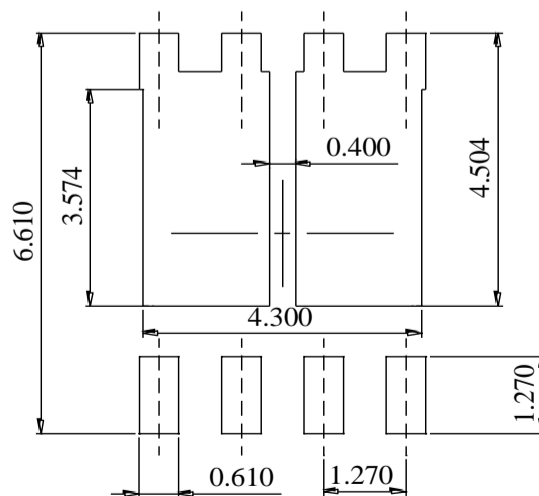

DIMENSIONS: MILLIMETERS