



650V SuperJunction Power MOSFET

Features

- Extremely Low Gate Charge
- Excellent Output Capacitance (C_{oss}) Profile
- Fast Switching Capability
- Fast Recovery Body Diode
- 100% UIS Tested, 100% R_g Tested
- Pb-free Lead Plating
- Halogen-free and RoHS-compliant

Product Summary

Parameter	Value	Unit
V_{DS}	650	V
$V_{GS(th)}_{Typ}$	3.5	V
I_D (@ $V_{GS} = 10V$) ⁽¹⁾	20	A
$R_{DS(ON)}_{Typ}$ (@ $V_{GS} = 10V$)	170	mΩ
$E_{oss@400V}$	5.2	μJ

Applications

- Telecom / Server Power Supplies
- Industrial Power Supplies
- UPS / Solar
- Lighting / Charger / Adapter

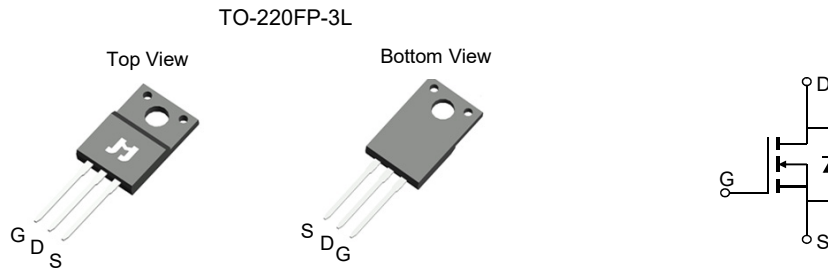

Ordering Information

Device	Package	# of Pins	Marking	MSL	T_J (°C)	Media	Quantity (pcs)
JMH65R190AFFD-U	TO-220FP-3L	3	H65R190AF	NA	-55 to 150	Tube	50

Absolute Maximum Ratings (@ $T_A = 25^\circ C$ unless otherwise specified)

Parameter	Symbol	Value	Unit
Drain-to-Source Voltage	V_{DS}	650	V
Gate-to-Source Voltage	V_{GS}	±30	V
Continuous Drain Current ⁽¹⁾	I_D	$T_C = 25^\circ C$	20
		$T_C = 100^\circ C$	13.0
Pulsed Drain Current ⁽²⁾	I_{DM}	75	A
Avalanche Current ⁽³⁾	I_{AS}	9.0	A
Avalanche Energy ⁽³⁾	E_{AS}	405	mJ
Power Dissipation ⁽⁴⁾	P_D	$T_C = 25^\circ C$	36
		$T_C = 100^\circ C$	14.3
Junction & Storage Temperature Range	T_J, T_{STG}	-55 to 150	°C

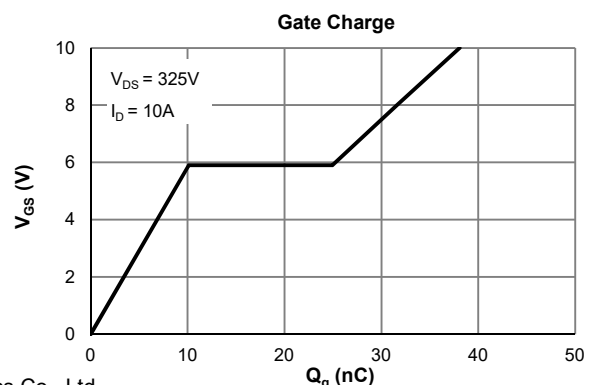
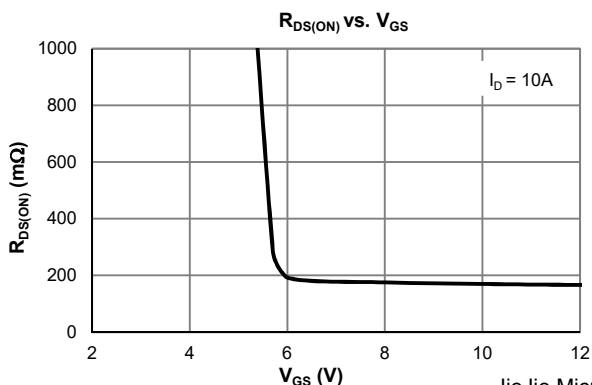



Electrical Characteristics (@ T_J = 25°C unless otherwise specified)

Parameter	Symbol	Conditions	Min.	Typ.	Max.	Unit
STATIC PARAMETERS						
Drain-Source Breakdown Voltage	V _{(BR)DSS}	I _D = 250μA, V _{GS} = 0V	650			V
Zero Gate Voltage Drain Current	I _{DSS}	V _{DS} = 650V, V _{GS} = 0V			1.0	μA
Gate-Body Leakage Current	I _{GSS}	V _{DS} = 0V, V _{GS} = ±30V			±100	nA
Gate Threshold Voltage	V _{GS(th)}	V _{DS} = V _{GS} , I _D = 250μA	2.5	3.5	4.5	V
Static Drain-Source ON-Resistance	R _{DS(ON)}	V _{GS} = 10V, I _D = 10A		170	190	mΩ
Diode Forward Voltage	V _{SD}	I _S = 1A, V _{GS} = 0V		0.75	1.0	V
Diode Continuous Current	I _S	T _C = 25°C			36	A
DYNAMIC PARAMETERS ⁽⁵⁾						
Input Capacitance	C _{iss}	V _{GS} = 0V, V _{DS} = 100V, f = 1MHz		1560		pF
Output Capacitance	C _{oss}			61		pF
Reverse Transfer Capacitance	C _{riss}			11.7		pF
Effective output capacitance, energy related	C _{o(er)}	V _{GS} = 0V, V _{DS} = 0 to 400V		65		pF
Effective output capacitance, time related	C _{o(tr)}			274		pF
Gate Resistance	R _g	V _{GS} = 0V, V _{DS} = 0V, f = 1MHz		8.9		Ω
SWITCHING PARAMETERS ⁽⁵⁾						
Total Gate Charge (@ V _{GS} = 10V)	Q _g	V _{GS} = 0 to 10V V _{DS} = 325V, I _D = 10A		38		nC
Gate Source Charge	Q _{gs}			10.1		nC
Gate Drain Charge	Q _{gd}			14.8		nC
Turn-On DelayTime	t _{D(on)}	V _{GS} = 10V, V _{DS} = 325V R _L = 32.5Ω, R _{GEN} = 6Ω		17.8		ns
Turn-On Rise Time	t _r			22		ns
Turn-Off DelayTime	t _{D(off)}			257		ns
Turn-Off Fall Time	t _f			20		ns
Body Diode Reverse Recovery Time	t _{rr}	I _F = 10A, di _F /dt = 100A/μS		120		ns
Body Diode Reverse Recovery Charge	Q _{rr}	I _F = 10A, di _F /dt = 100A/μS		4.4		μC
Peak Diode Recovery Voltage Slope	dv/dt	I _F ≤ 10A, di _F /dt = 200A/us, V _{DS} = 400V		15		V/ns
MOSFET dv/dt Ruggedness	dv/dt	V _{DS} = 0...400V		50		V/ns

Thermal Performance

Parameter	Symbol	Typ.	Max.	Unit
Thermal Resistance, Junction-to-Ambient	R _{θJA}	52	62	°C/W
Thermal Resistance, Junction-to-Case	R _{θJC}	3.5	4.2	°C/W

Notes:

- Limited by T_J max. on duty cycle D=0.5.
- This single-pulse measurement was taken under T_{J,Max} = 150°C.
- This single-pulse measurement was taken under the following condition [L = 10mH, V_{GS} = 10V, V_{DS} = 50V] while its value is limited by T_{J,Max} = 150°C.
- The power dissipation P_D is based on T_{J,Max} = 150°C.
- This value is guaranteed by design hence it is not included in the production test.

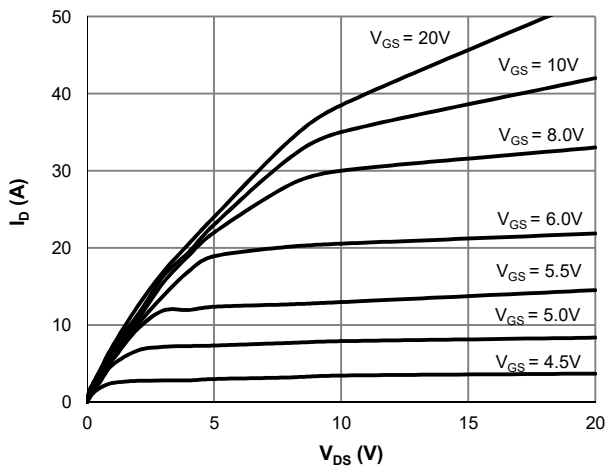
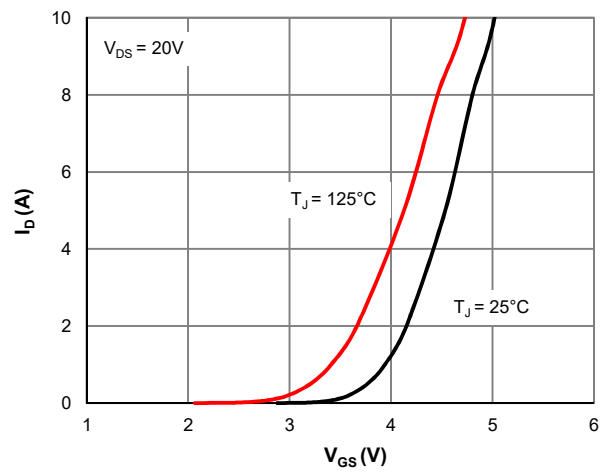
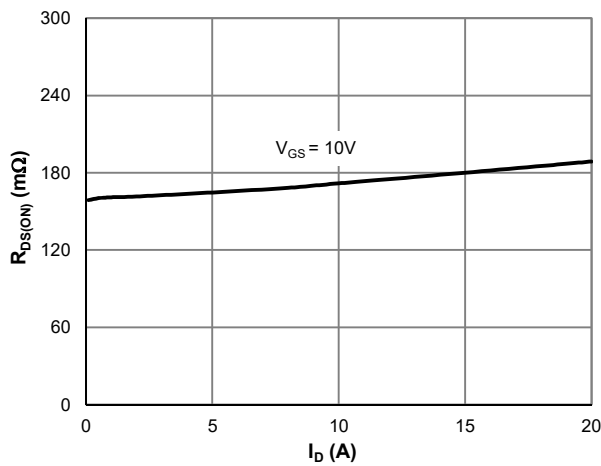
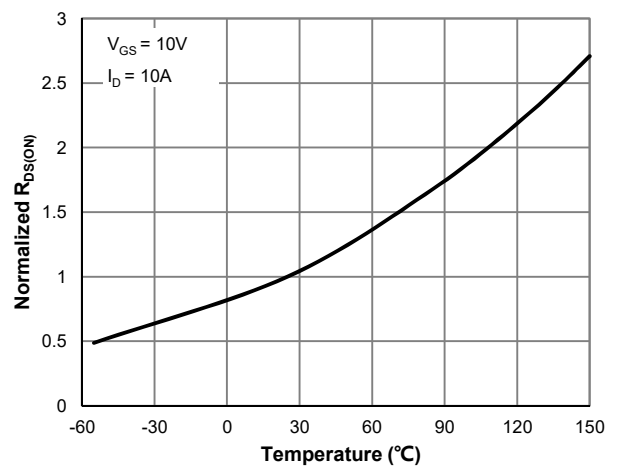
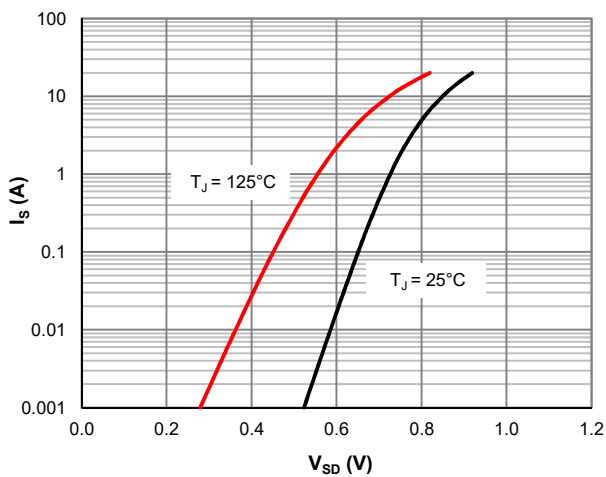
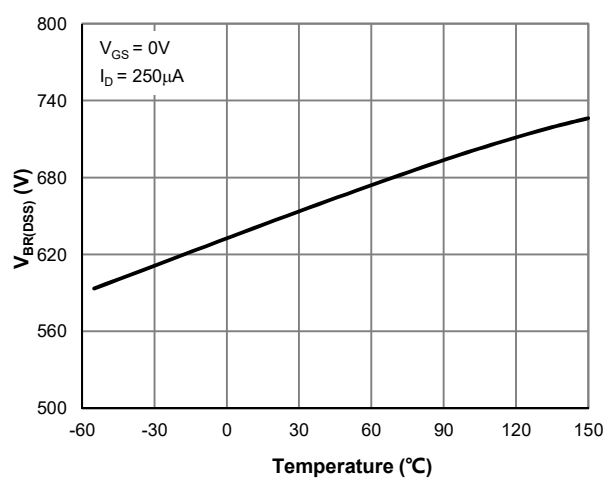
Typical Electrical & Thermal Characteristics

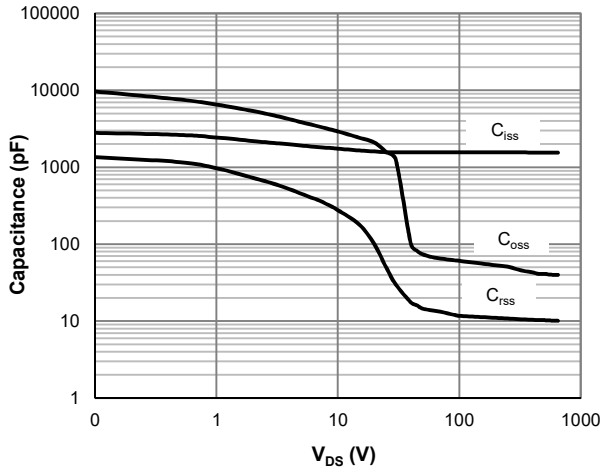
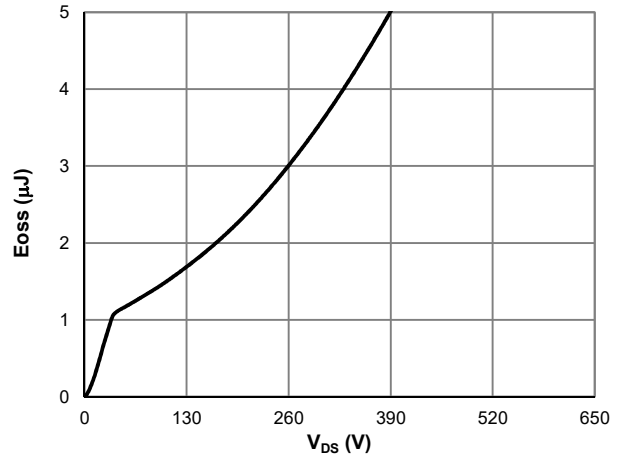
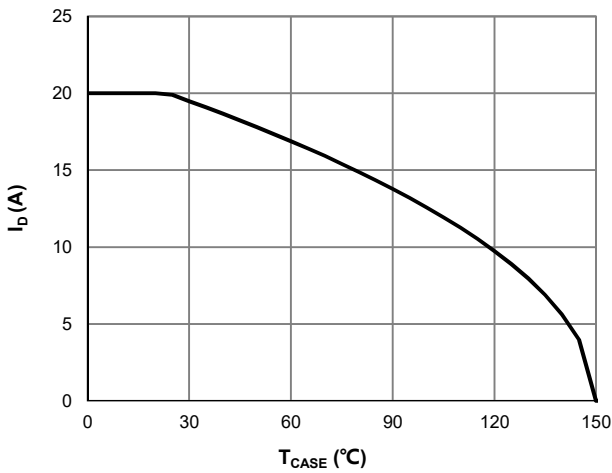
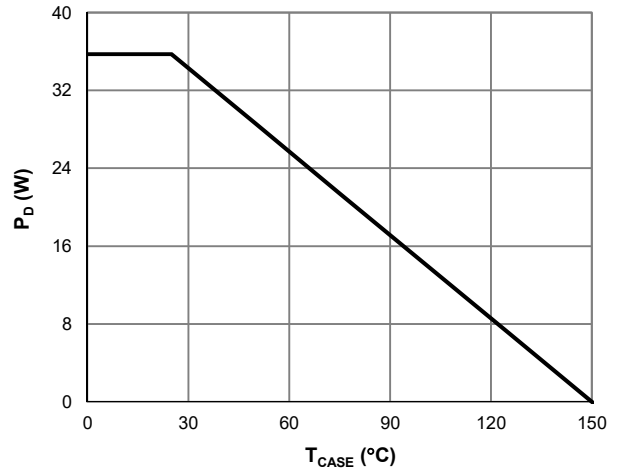
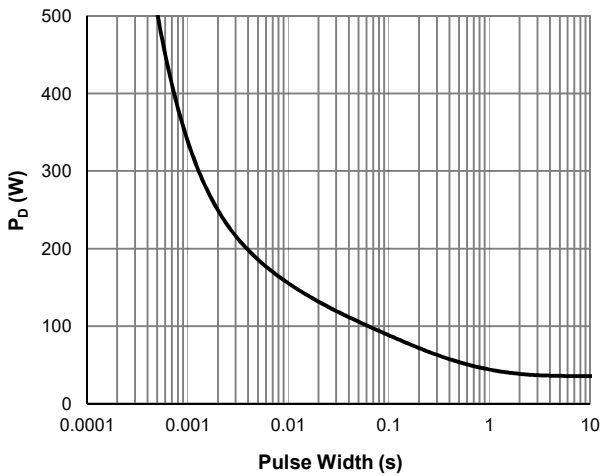
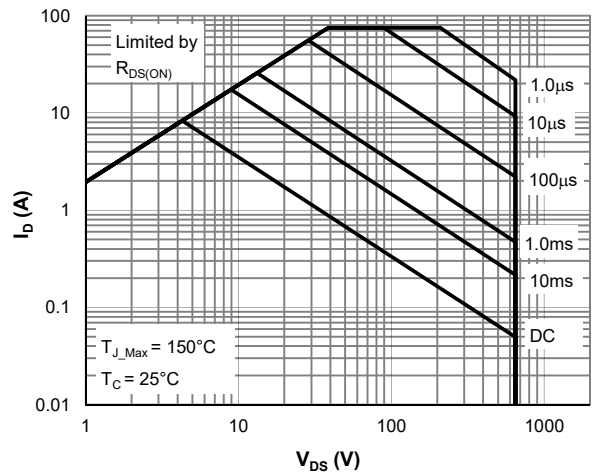
Figure 1: Saturation Characteristics

Figure 2: Transfer Characteristics

Figure 3: $R_{DS(ON)}$ vs. Drain Current

Figure 4: $R_{DS(ON)}$ vs. Junction Temperature

Figure 5: Body-Diode Characteristics

Figure 6: $V_{BR(DSS)}$ vs. Junction Temperature

Typical Electrical & Thermal Characteristics

Figure 7: Capacitance Characteristics

Figure 8: Coss Stored Energy

Figure 9: Current De-rating

Figure 10: Power De-rating

Figure 11: Single Pulse Power Rating, Junction-to-Case

Figure 12: Maximum Safe Operating Area



Typical Electrical & Thermal Characteristics

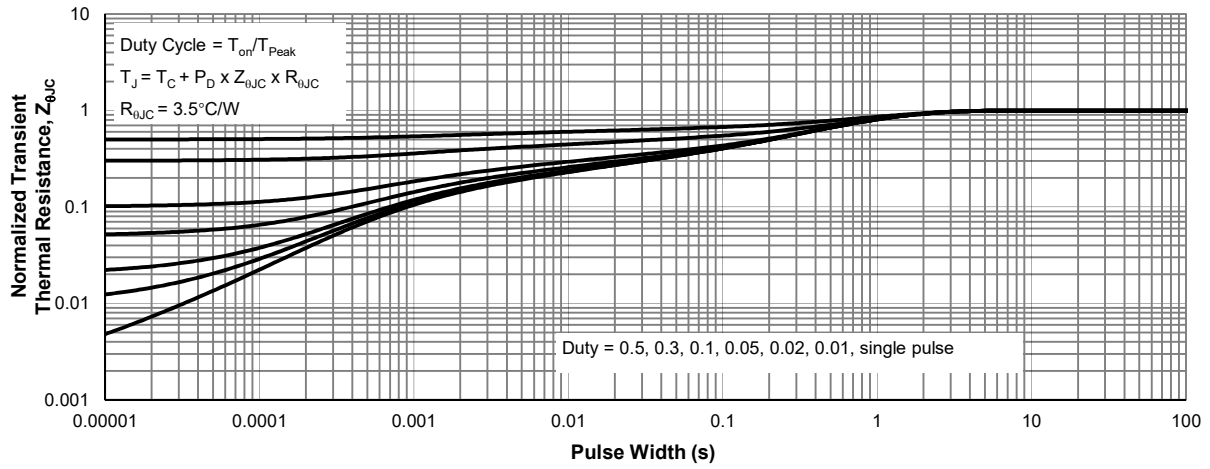
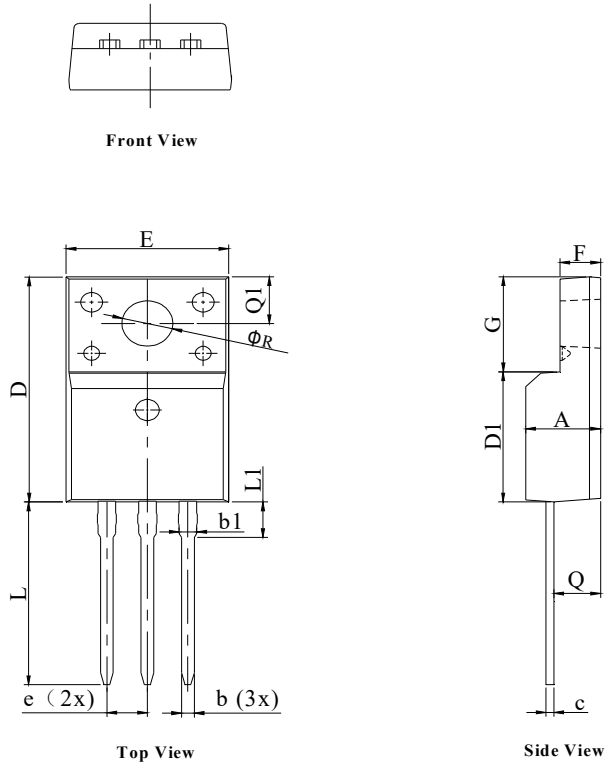

Figure 13: Normalized Maximum Transient Thermal Impedance

TO-220FP-3L Package Information
Package Outline

DIM.	MILLIMETER		
	MIN.	NOM.	MAX.
A	4.50	4.70	4.90
D	15.20	15.87	16.10
D1	8.80	--	9.50
E	9.70	10.10	10.40
F	2.44	--	2.75
b	0.70	0.80	0.91
b1	1.10	1.35	1.55
c	0.45	0.50	0.65
e	2.54 BSC		
G	6.40	6.70	6.90
L	12.00	13.10	14.50
L1	3.13	--	3.57
Q	2.60	2.75	2.85
Q1	3.20	3.30	3.40
R	3.05	--	3.28