



**80V 3.3mΩ N-Ch Power MOSFET**

**Features**

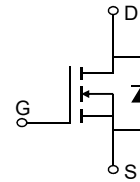
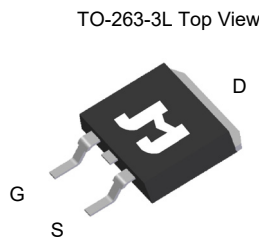
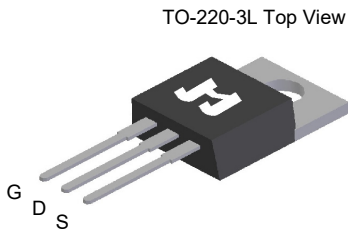
- Ultra-low  $R_{DS(ON)}$
- Low Gate Charge
- 100% UIS Tested, 100%  $R_g$  Tested
- Pb-free Lead Plating
- Halogen-free and RoHS-compliant

**Product Summary**

Parameter	Value	Unit
$V_{DS}$	80	V
$V_{GS(th)}$	3.0	V
$I_D$ (@ $V_{GS} = 10V$ ) <sup>(1)</sup>	158	A
$R_{DS(ON)}$ (@ $V_{GS} = 10V$ )	3.3	mΩ

**Applications**

- Motor Driving in Power Tool, E-vehicle, Robotics
- Current Switching in DC/DC & AC/DC (SR) Sub-systems
- Power Management in Telecom., Industrial Automation, CE

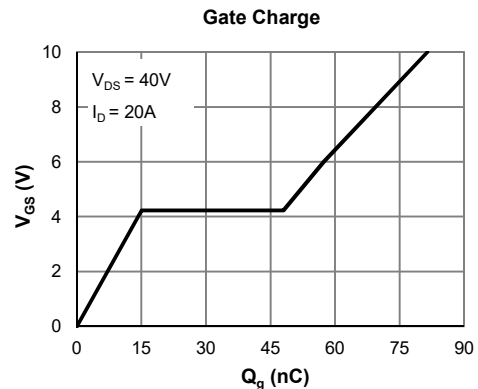
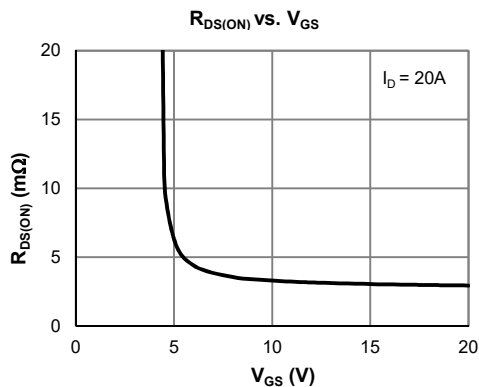


**Ordering Information**

Device	Package	# of Pins	Marking	MSL	$T_J$ (°C)	Media	Quantity (pcs)
JMSH0804NC-U	TO-220-3L	3	SH0804N	NA	-55 to 150	Tube	50
JMSH0804NE-13	TO-263-3L	3	SH0804N	1	-55 to 150	13-inch Reel	800

**Absolute Maximum Ratings** (@  $T_A = 25^\circ\text{C}$  unless otherwise specified)

Parameter	Symbol	Value	Unit
Drain-to-Source Voltage	$V_{DS}$	80	V
Gate-to-Source Voltage	$V_{GS}$	$\pm 20$	V
Continuous Drain Current <sup>(1)</sup>	$I_D$	$T_C = 25^\circ\text{C}$	158
		$T_C = 100^\circ\text{C}$	99
Pulsed Drain Current <sup>(2)</sup>	$I_{DM}$	511	A
Avalanche Energy <sup>(3)</sup>	$E_{AS}$	434	mJ
Power Dissipation <sup>(4)</sup>	$P_D$	$T_C = 25^\circ\text{C}$	192
		$T_C = 100^\circ\text{C}$	76
Junction & Storage Temperature Range	$T_J, T_{STG}$	-55 to 150	°C





**Electrical Characteristics** (@  $T_J = 25^\circ\text{C}$  unless otherwise specified)

Parameter	Symbol	Conditions	Min.	Typ.	Max.	Unit
<b>STATIC PARAMETERS</b>						
Drain-Source Breakdown Voltage	$V_{(BR)DSS}$	$I_D = 250\mu\text{A}, V_{GS} = 0\text{V}$	80	90		V
Zero Gate Voltage Drain Current	$I_{DSS}$	$V_{DS} = 64\text{V}, V_{GS} = 0\text{V}$ $T_J = 55^\circ\text{C}$			1.0 5.0	$\mu\text{A}$
Gate-Body Leakage Current	$I_{GSS}$	$V_{DS} = 0\text{V}, V_{GS} = \pm 20\text{V}$			$\pm 100$	nA
Gate Threshold Voltage	$V_{GS(th)}$	$V_{DS} = V_{GS}, I_D = 250\mu\text{A}$	2.0	3.0	4.0	V
Static Drain-Source ON-Resistance	$R_{DS(on)}$	$V_{GS} = 10\text{V}, I_D = 20\text{A}$	TO-263-3L	3.3	4.2	$\text{m}\Omega$
			TO-220-3L	3.5	4.4	$\text{m}\Omega$
Forward Transconductance	$g_{FS}$	$V_{DS} = 5\text{V}, I_D = 20\text{A}$		58		S
Diode Forward Voltage	$V_{SD}$	$I_S = 1\text{A}, V_{GS} = 0\text{V}$		0.68	1.0	V
Diode Continuous Current	$I_S$	$T_C = 25^\circ\text{C}$			158	A
<b>DYNAMIC PARAMETERS</b> <sup>(5)</sup>						
Input Capacitance	$C_{iss}$	$V_{GS} = 0\text{V}, V_{DS} = 40\text{V}, f = 1\text{MHz}$		3503		pF
Output Capacitance	$C_{oss}$			1048		pF
Reverse Transfer Capacitance	$C_{rss}$			23		pF
Gate Resistance	$R_g$	$V_{GS} = 0\text{V}, V_{DS} = 0\text{V}, f = 1\text{MHz}$		1.5		$\Omega$
<b>SWITCHING PARAMETERS</b> <sup>(5)</sup>						
Total Gate Charge (@ $V_{GS} = 10\text{V}$ )	$Q_g$	$V_{GS} = 0 \text{ to } 10\text{V}$ $V_{DS} = 40\text{V}, I_D = 20\text{A}$		82		nC
Total Gate Charge (@ $V_{GS} = 6.0\text{V}$ )	$Q_g$			57		nC
Gate Source Charge	$Q_{gs}$			15.0		nC
Gate Drain Charge	$Q_{gd}$			33		nC
Turn-On Delay Time	$t_{D(on)}$	$V_{GS} = 10\text{V}, V_{DS} = 40\text{V}$ $R_L = 2.0\Omega, R_{GEN} = 3\Omega$		14.9		ns
Turn-On Rise Time	$t_r$			35		ns
Turn-Off Delay Time	$t_{D(off)}$			50		ns
Turn-Off Fall Time	$t_f$			37		ns
Body Diode Reverse Recovery Time	$t_{rr}$		$I_F = 20\text{A}, dI_F/dt = 100\text{A}/\mu\text{s}$		70	
Body Diode Reverse Recovery Charge	$Q_{rr}$	$I_F = 20\text{A}, dI_F/dt = 100\text{A}/\mu\text{s}$		61		nC

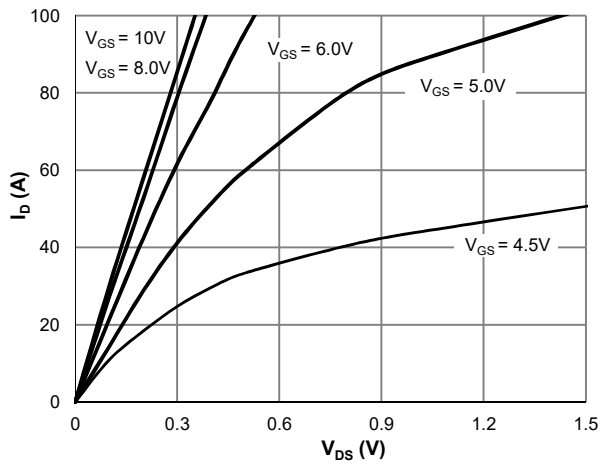
**Thermal Performance**

Parameter	Symbol	Typ.	Max.	Unit
Thermal Resistance, Junction-to-Ambient	$R_{\theta JA}$	45	55	$^\circ\text{C}/\text{W}$
Thermal Resistance, Junction-to-Case	$R_{\theta JC}$	0.65	0.8	$^\circ\text{C}/\text{W}$

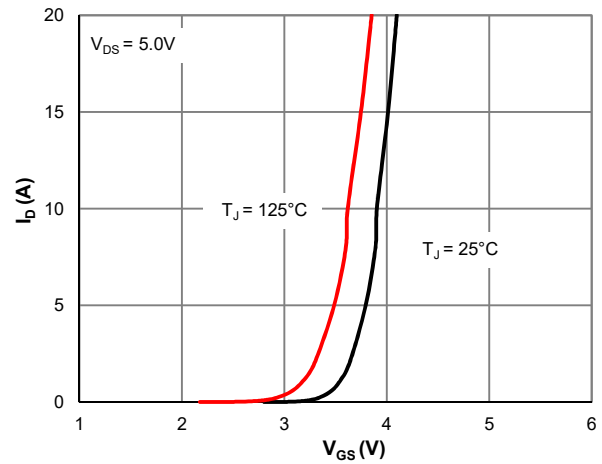
**Notes:**

1. Computed continuous current assumes the condition of  $T_{J\_Max}$  while the actual continuous current depends on the thermal & electro-mechanical application board design.
2. This single-pulse measurement was taken under  $T_{J\_Max} = 150^\circ\text{C}$ .
3.  $E_{AS}$  of 434 mJ is based on starting  $T_J = 25^\circ\text{C}$ ,  $L = 3.0\text{mH}$ ,  $I_{AS} = 17\text{A}$ ,  $V_{GS} = 10\text{V}$ ,  $V_{DD} = 40\text{V}$ ; 100% test at  $L = 0.3\text{mH}$ ,  $I_{AS} = 40\text{A}$ ,  $T_{J\_Max} = 150^\circ\text{C}$ .
4. The power dissipation  $P_D$  is based on  $T_{J\_Max} = 150^\circ\text{C}$ .
5. This value is guaranteed by design hence it is not included in the production test.

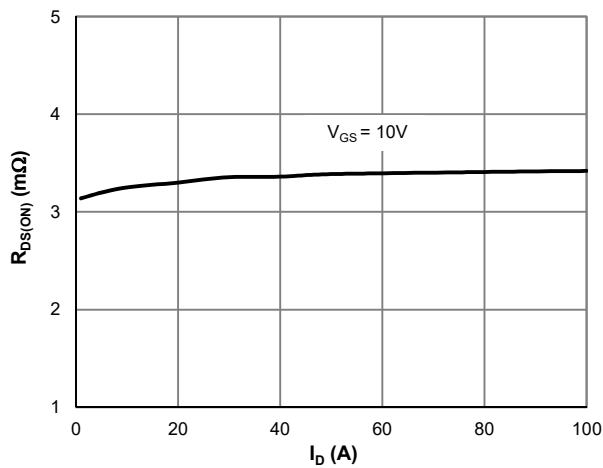
**Typical Electrical & Thermal Characteristics**



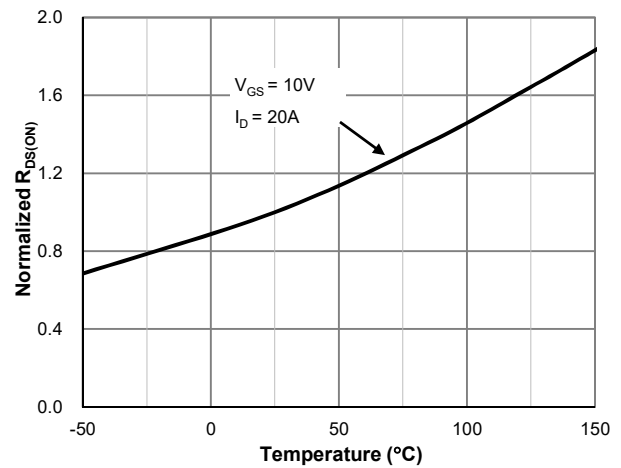
**Figure 1: Saturation Characteristics**



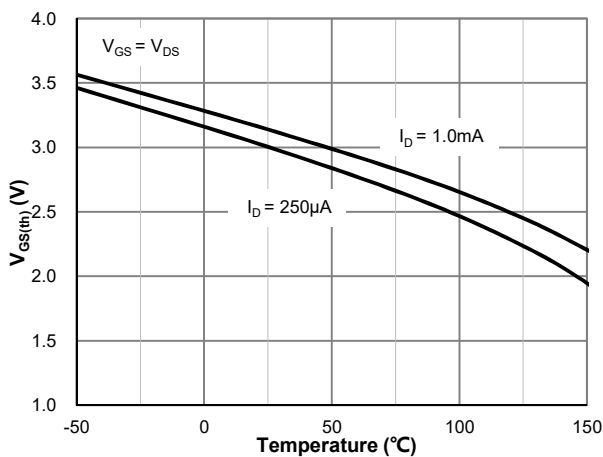
**Figure 2: Transfer Characteristics**



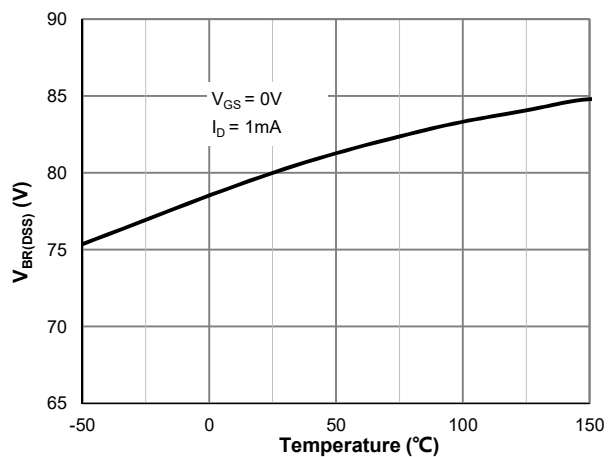
**Figure 3:  $R_{DS(ON)}$  vs. Drain Current**



**Figure 4:  $R_{DS(ON)}$  vs. Junction Temperature**

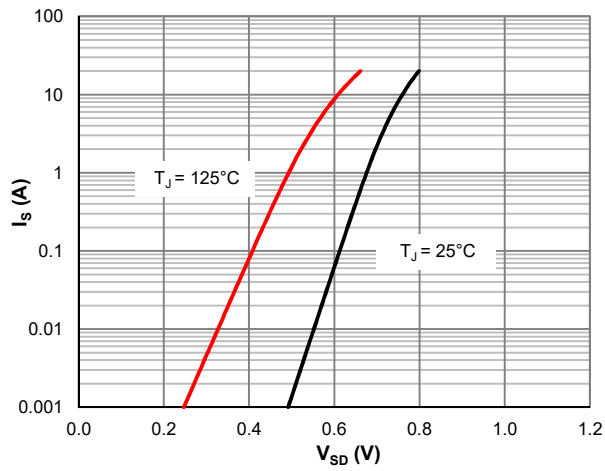


**Figure 5:  $V_{GS(th)}$  vs. Junction Temperature**

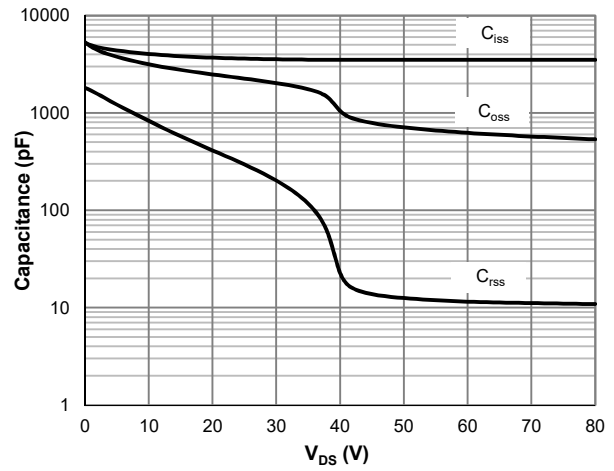


**Figure 6:  $V_{BR(DSS)}$  vs. Junction Temperature**

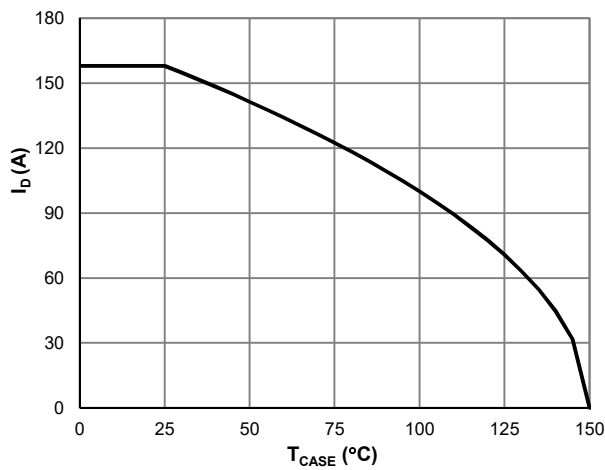
**Typical Electrical & Thermal Characteristics**



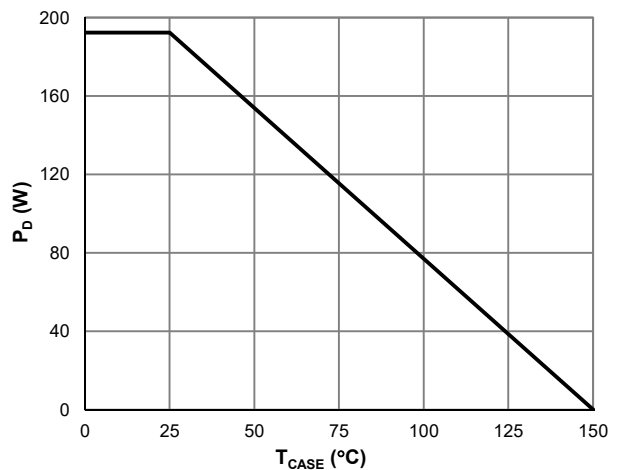
**Figure 7: Body-Diode Characteristics**



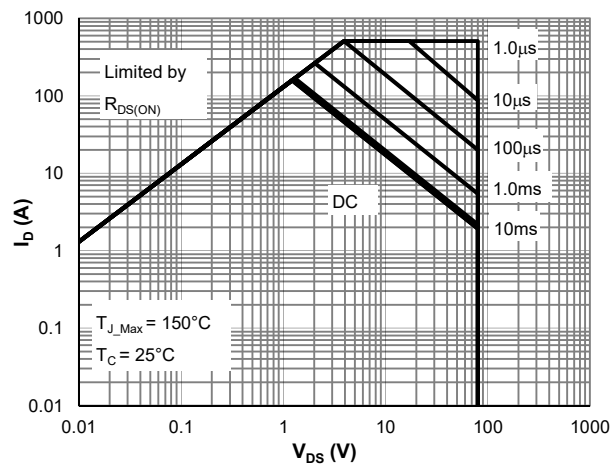
**Figure 8: Capacitance Characteristics**



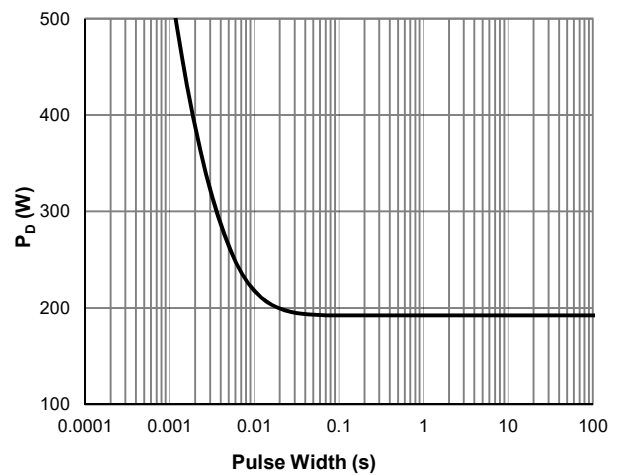
**Figure 9: Current De-rating**



**Figure 10: Power De-rating**



**Figure 11: Maximum Safe Operating Area**



**Figure 12: Single Pulse Power Rating, Junction-to-Case**



### Typical Electrical & Thermal Characteristics

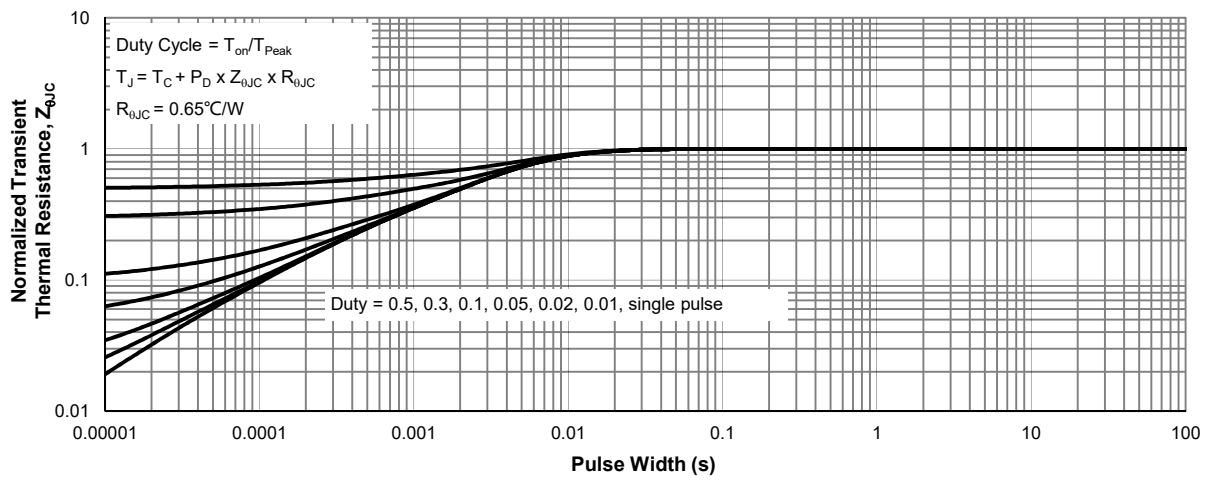
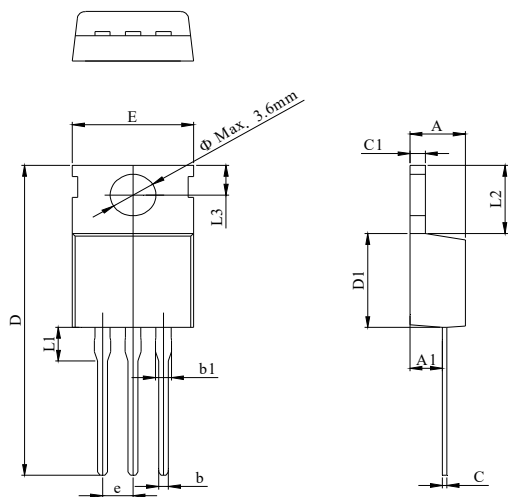


Figure 13: Normalized Maximum Transient Thermal Impedance

**TO-220-3L Package Information**

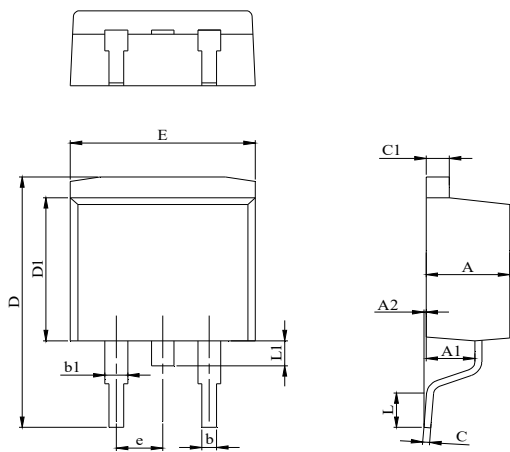
**Package Outline**



DIM.	MILLIMETER		
	MIN.	NOM.	MAX.
A	4.24		4.70
A1	2.20		3.00
b	0.70		0.95
b1	1.14		1.70
C	0.40		0.60
C1	1.15		1.40
D	28.00		29.80
D1	8.80		9.90
E	9.70		10.50
L1			3.80
L2	6.25		6.90
L3	2.40		3.00
e		2.54 BSC	

**TO-263-3L Package Information**

**Package Outline**



DIM.	MILLIMETER		
	MIN.	NOM.	MAX.
A	4.24		4.77
A1	2.30		2.89
A2	0.00	0.10	0.25
b	0.70		0.96
b1	1.17		1.70
C	0.30		0.60
C1	1.15		1.42
D	14.10		15.88
D1	8.50		9.60
E	9.78		10.36
L	1.78		2.79
L1			1.75
e		2.54	

**Recommend Soldering Footprint**

