

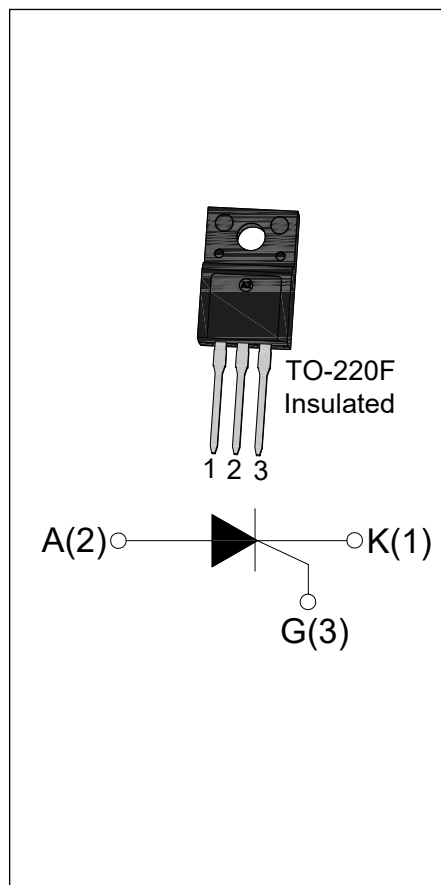

DESCRIPTION:

With high ability to withstand the shock loading of large current, JCT1225F SCRs provide high dv/dt rate with strong resistance to electromagnetic interference. They are especially recommended for use on solid state relay, motorcycle, power charger, T-tools etc.

From all three terminals to external heatsink, JCT1225F provides a rated insulation voltage of 2000 V_{RMS}, complying with UL standards (File ref: E252906). Package TO-220F is RoHS compliant. (2011/65/EU)



MAIN FEATURES

Symbol	Value	Symbol
V _{DRM} / V _{R_{RRM}}	1200	V
I _{T(RMS)}	25	A
I _{GT}	≤35	mA

ABSOLUTE MAXIMUM RATINGS

Parameter		Symbol	Value	Unit
Storage junction temperature range		T _{stg}	-40-150	°C
Operating junction temperature range		T _j	-40-125	°C
Repetitive peak off-state voltage(T _j =25°C)		V _{DRM}	1200	V
Repetitive peak reverse voltage(T _j =25°C)		V _{R_{RRM}}	1200	V
RMS on-state current	TO-220F(Ins) (T _c =50°C)	I _{T(RMS)}	25	A
Non repetitive surge peak on-state current (tp=10ms)		I _{TSM}	250	A
I ² t value for fusing (tp=10ms)		I ² t	310	A ² s
Critical rate of rise of on-state current (I _G =2×I _{GT})		di/dt	100	A/μs
Peak gate current		I _{GM}	1.5	A

Average gate power dissipation	$P_{G(AV)}$	2	W
Peak gate power	P_{GM}	5	W

ELECTRICAL CHARACTERISTICS ($T_j=25^\circ\text{C}$ unless otherwise specified)

Symbol	Test Condition	Value			Unit
		MIN.	TYP.	MAX.	
I_{GT}	$V_D=12\text{V } R_L=33\Omega$	-	-	35	mA
V_{GT}		-	-	1.5	V
V_{GD}	$V_D=V_{DRM} T_j=125^\circ\text{C } R_L=3.3\text{K}\Omega$	0.25	-	-	V
I_L	$I_G=1.2I_{GT}$	-	-	150	mA
I_H	$I_T=500\text{mA}$	-	-	120	mA
dv/dt	$V_D=2/3V_{DRM}$ Gate Open $T_j=125^\circ\text{C}$	1000	-	-	V/ μs

STATIC CHARACTERISTICS

Symbol	Parameter		Value(MAX)	Unit
V_{TM}	$I_{TM}=50\text{A } t_p=380\mu\text{s}$	$T_j=25^\circ\text{C}$	1.8	V
V_{TO}	Threshold voltage	$T_j=125^\circ\text{C}$	0.96	V
R_D	Dynamic resistance	$T_j=125^\circ\text{C}$	16	m Ω
I_{DRM}	$V_D=V_{DRM} V_R=V_{RRM}$	$T_j=25^\circ\text{C}$	10	μA
I_{RRM}		$T_j=125^\circ\text{C}$	4	mA

THERMAL RESISTANCES

Symbol	Parameter		Value	Unit
$R_{th(j-c)}$	junction to case(AC)	TO-220F(Ins)	2.3	$^\circ\text{C/W}$

ORDERING INFORMATION

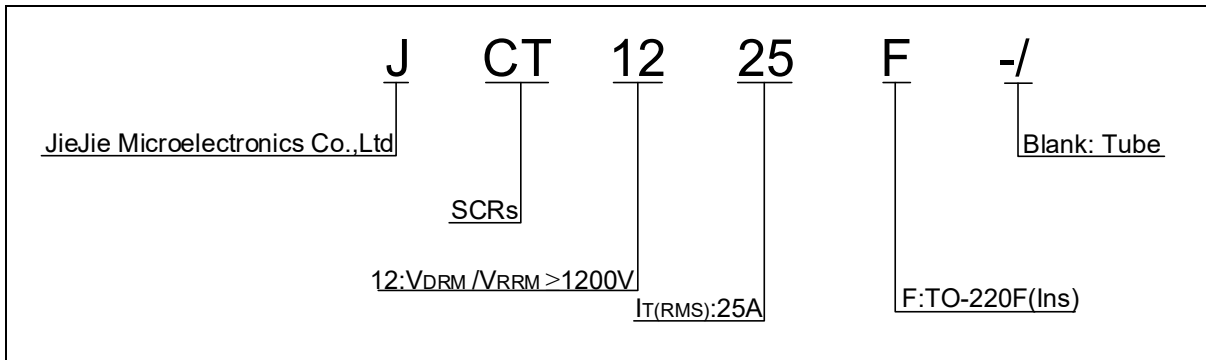

FIG.1 Maximum power dissipation versus RMS on-state current

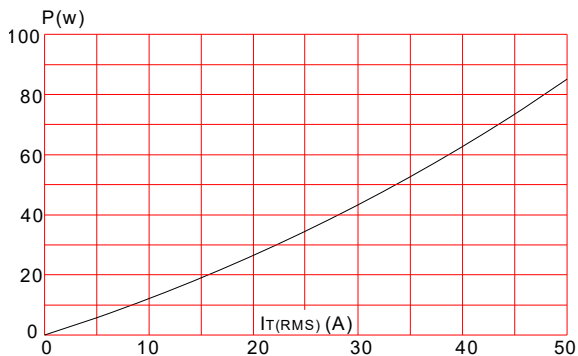

FIG.3: Surge peak on-state current versus number of cycles

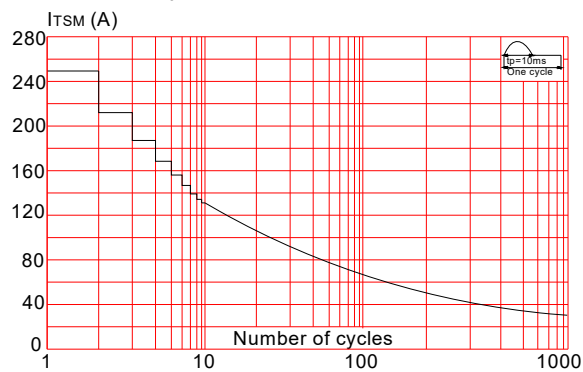

FIG.5: Non-repetitive surge peak on-state current for a sinusoidal pulse with width $t_p < 10ms$, and corresponding value of I^2t ($di/dt < 100A/\mu s$)

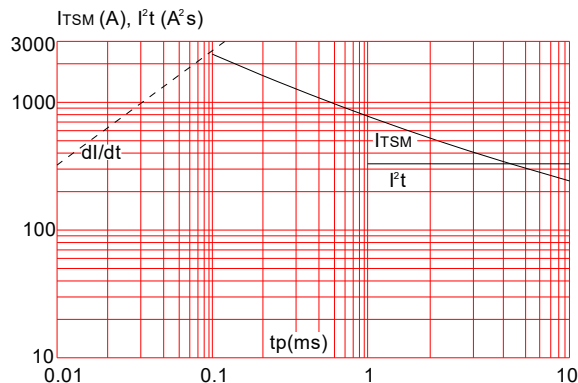

FIG.2: RMS on-state current versus case temperature

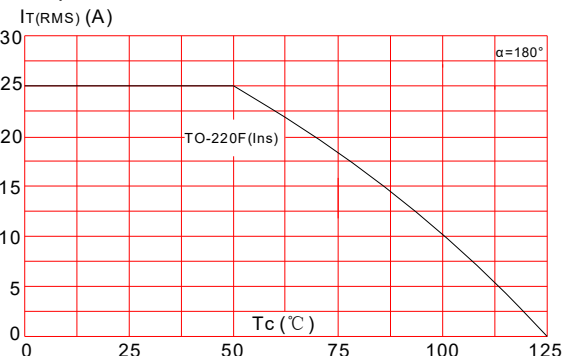

FIG.4: On-state characteristics (maximum values)

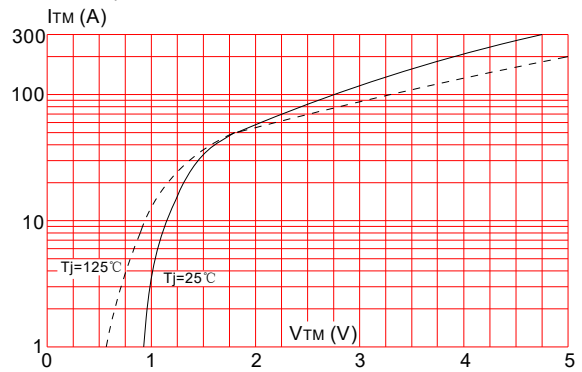
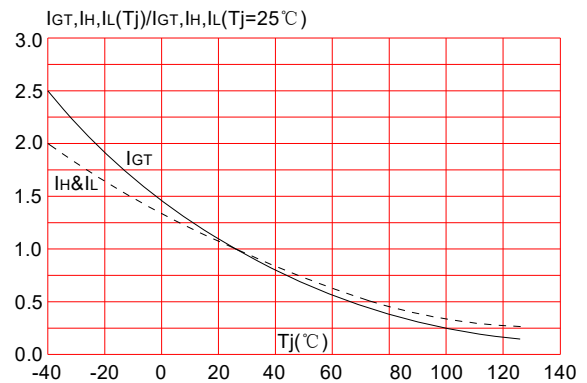

FIG.6: Relative variations of gate trigger current, holding current and latching current versus junction temperature



ORDERING INFORMATION

Order code	Voltage $V_{\text{DRM}}/V_{\text{RRM}}$ (V)	IGT(mA)	Package	Base qty. (pcs)	Delivery mode
JCT1225F	1200	35	TO-220F(Ins)	50	Tube

Document Revision History

Date	Revision	Changes
Dec 9, 2020	9	Last update
Dec 23, 2021	9	Add V_{TO} & R_{D}

PACKAGE MECHANICAL DATA

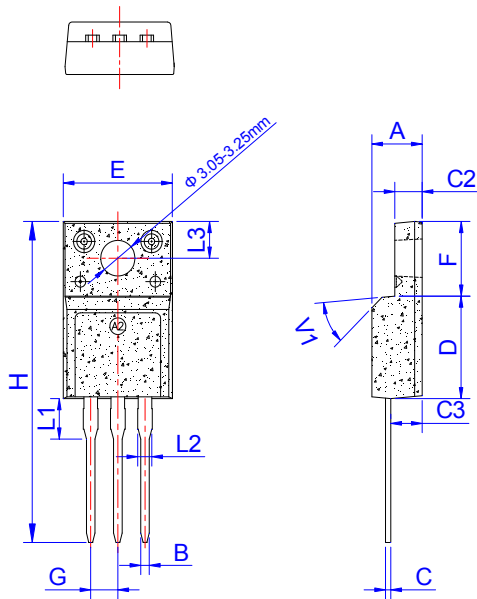

Ref.	Dimensions					
	Millimeters			Inches		
	Min.	Typ.	Max.	Min.	Typ.	Max.
A	4.50		4.90	0.177		0.193
B	0.74	0.80	0.83	0.029	0.031	0.033
C	0.47		0.65	0.019		0.026
C2	2.45		2.75	0.096		0.108
C3	2.60		3.00	0.102		0.118
D	8.80		9.30	0.346		0.366
E	9.80		10.4	0.386		0.410
F	6.40		6.80	0.252		0.268
G	2.40		2.70	0.094		0.106
H	28.0		29.8	1.102		1.173
L1		3.63			0.143	
L2		1.14			0.045	
L3		3.30			0.130	
V1		45°			45°	

DELIVERY MODE

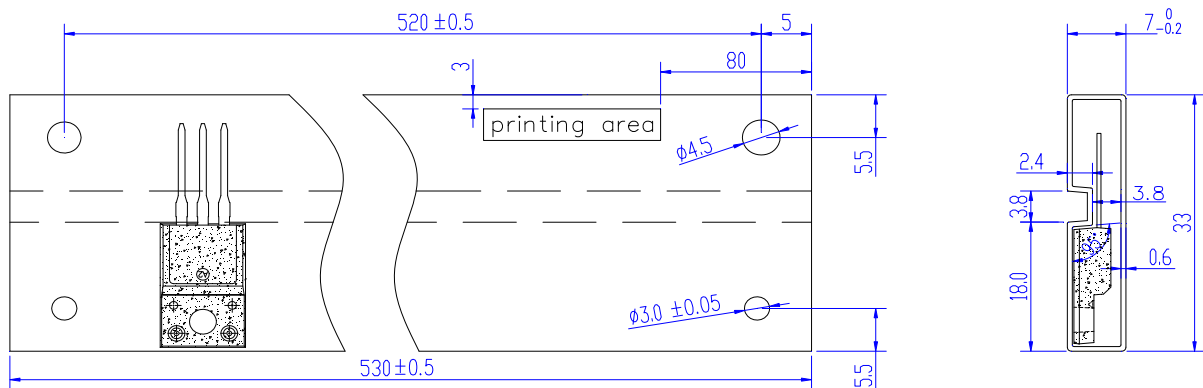

PACKAGE	OUTLINE	TUBE (PCS)	INNER BOX (PCS)	PER CARTON
TO-220F	TUBE	50	1,000	5,000



Information furnished in this document is believed to be accurate and reliable. However, Jiangsu JieJie Microelectronics Co.,Ltd assumes no responsibility for the consequences of use without consideration for such information nor use beyond it. Information mentioned in this document is subject to change without notice, apart from that when an agreement is signed, Jiangsu JieJie complies with the agreement. Products and information provided in this document have no infringement of patents. Jiangsu JieJie assumes no responsibility for any infringement of other rights of third parties which may result from the use of such products and information. This document supersedes and replaces all information previously supplied.

 is a registered trademark of Jiangsu JieJie Microelectronics Co.,Ltd.

Copyright ©2022 Jiangsu JieJie Microelectronics Co.,Ltd. Printed All rights reserved.