

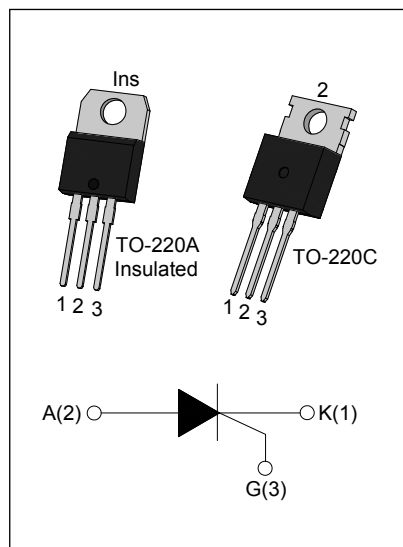

### DESCRIPTION:

With high ability to withstand the shock loading of large current, JCT1240 provide high dv/dt rate with strong resistance to electromagnetic interference. They are especially recommended for use on solid state relay, motorcycle, power charger, T-tools etc. From all three terminals to external heatsink, JCT1240A provide a rated insulation voltage of 2500 V<sub>RMS</sub>, complying with UL standards (File ref: E252906). Package TO-220A & TO-220C are RoHS compliant. (2011/65/EU)



### MAIN FEATURES

Symbol	JCT1240
V <sub>DRM</sub> / V <sub>RRM</sub>	1200V
I <sub>T(RMS)</sub>	40A
I <sub>GT</sub>	≤45mA

### ABSOLUTE MAXIMUM RATINGS

Parameter	Symbol	Value	Unit
Storage junction temperature range	T <sub>stg</sub>	-40-150	°C
Operating junction temperature range	T <sub>j</sub>	-40-125	°C
Repetitive peak off-state voltage(T <sub>j</sub> =25°C)	V <sub>DRM</sub>	1200	V
Repetitive peak reverse voltage(T <sub>j</sub> =25°C)	V <sub>RRM</sub>	1200	V
RMS on-state current	TO-220A(Ins) (T <sub>C</sub> =80°C)	40	A
	TO-220C (T <sub>C</sub> =95°C)		
Non repetitive surge peak on-state current (tp=10ms)	I <sub>TSM</sub>	400	A
I <sup>2</sup> t value for fusing (tp=10ms)	I <sup>2</sup> t	800	A <sup>2</sup> s
Critical rate of rise of on-state current (I <sub>G</sub> =2×I <sub>GT</sub> )	dI/dt	150	A/μs

Peak gate current	$I_{GM}$	4	A
Average gate power dissipation	$P_{G(AV)}$	1	W
Peak gate power	$P_{GM}$	5	W

**ELECTRICAL CHARACTERISTICS** ( $T_j=25^{\circ}C$  unless otherwise specified)

Symbol	Test Condition	Value			Unit
		MIN.	TYP.	MAX.	
$I_{GT}$	$V_D=12V R_L=33\Omega$	-	15	45	mA
$V_{GT}$		-	-	1.5	V
$V_{GD}$	$V_D=V_{DRM} T_j=125^{\circ}C R_L=3.3K\Omega$	0.2	-	-	V
$I_L$	$I_G=1.2I_{GT}$	-	-	150	mA
$I_H$	$I_T=500mA$	-	-	100	mA
dV/dt	$V_D=2/3V_{DRM}$ Gate Open $T_j=125^{\circ}C$	1000	-	-	V/ $\mu s$

**STATIC CHARACTERISTICS**

Symbol	Parameter		Value(MAX)	Unit
$V_{TM}$	$I_{TM}=80A t_p=380\mu s$	$T_j=25^{\circ}C$	1.6	V
$I_{DRM}$	$V_D=V_{DRM} V_R=V_{RRM}$	$T_j=25^{\circ}C$	10	$\mu A$
$I_{RRM}$		$T_j=125^{\circ}C$	4	mA

**THERMAL RESISTANCES**

Symbol	Parameter		Value	Unit
$R_{th(j-c)}$	junction to case(AC)	TO-220A(Ins)	1.3	$^{\circ}C/W$
		TO-220C	0.7	

**ORDERING INFORMATION**

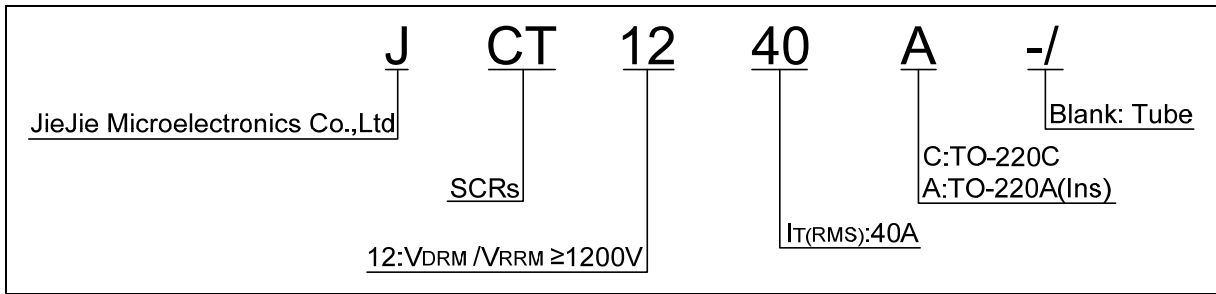

**ORDERING INFORMATION**

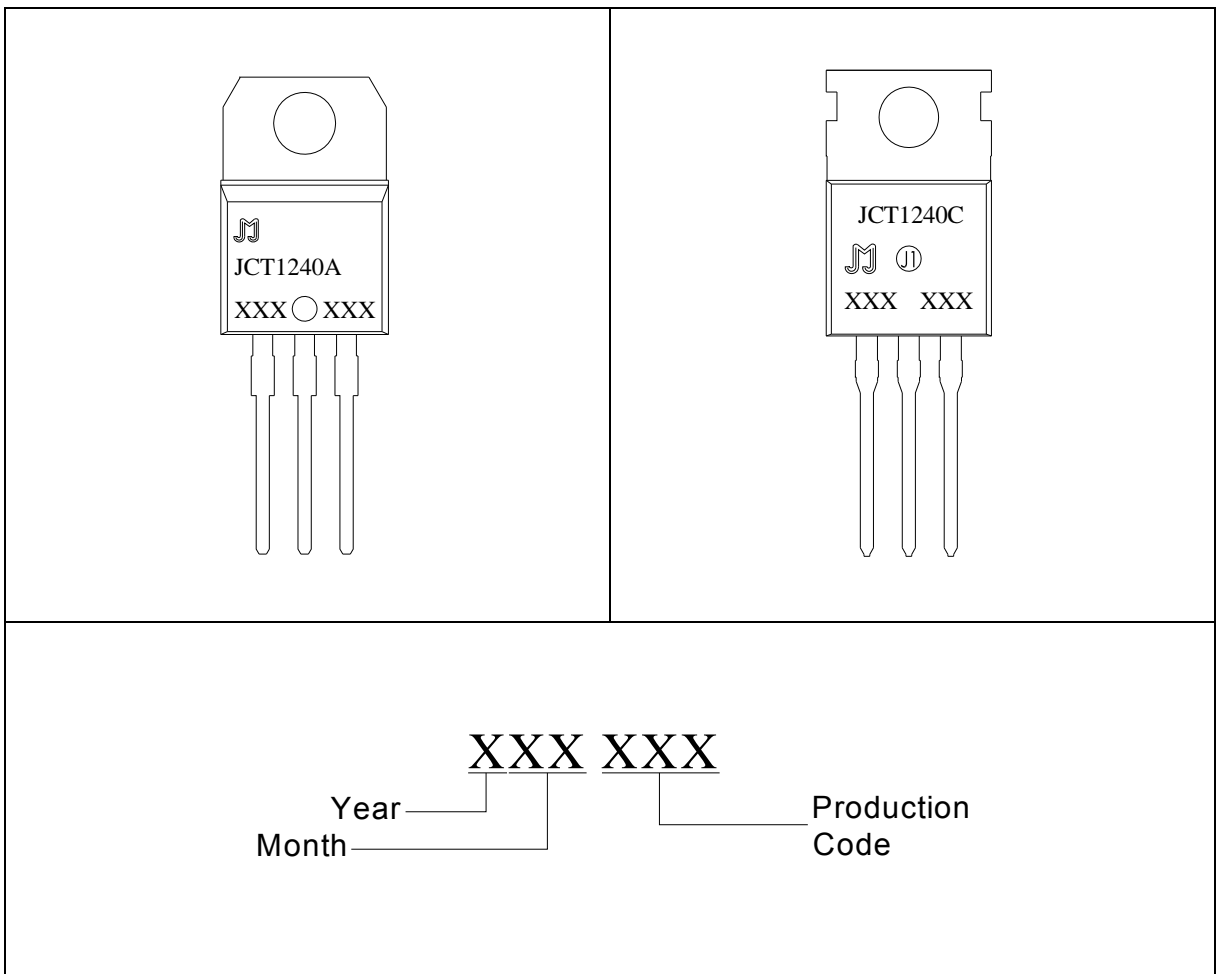

**FIG.1** Maximum power dissipation versus RMS on-state current

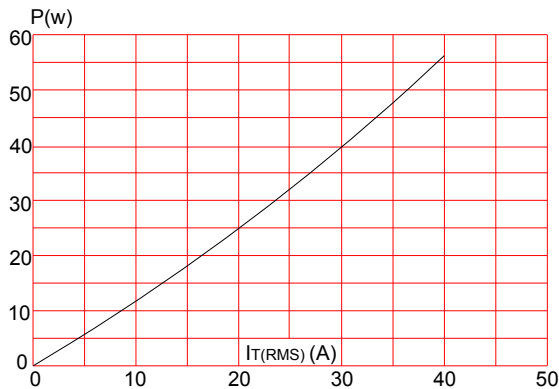

**FIG.3:** Surge peak on-state current versus number of cycles

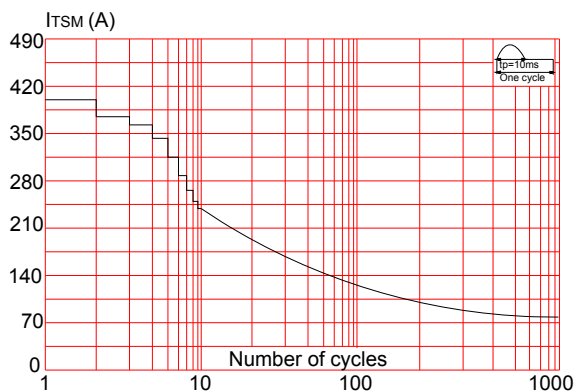

**FIG.5:** Non-repetitive surge peak on-state current for a sinusoidal pulse with width  $t_p < 10\text{ms}$ , and corresponding value of  $I^2t$  ( $di/dt < 150\text{A}/\mu\text{s}$ )

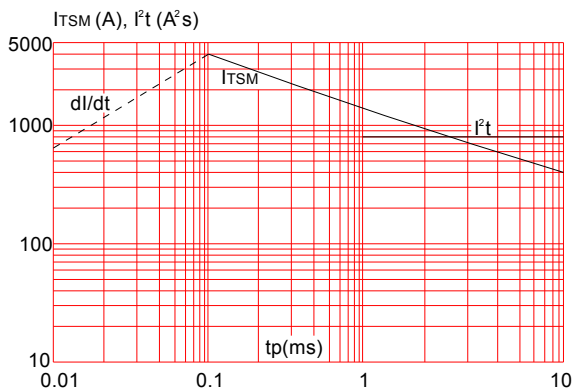

**FIG.2:** RMS on-state current versus case temperature

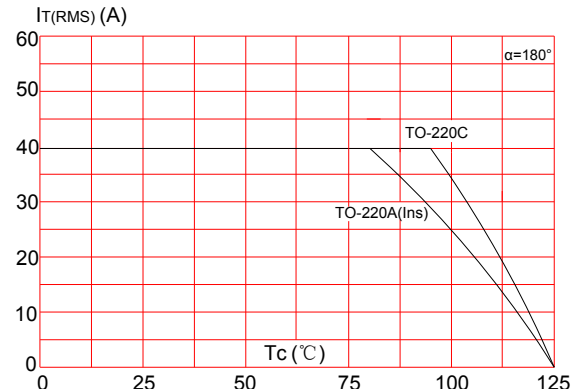

**FIG.4:** On-state characteristics (maximum values)

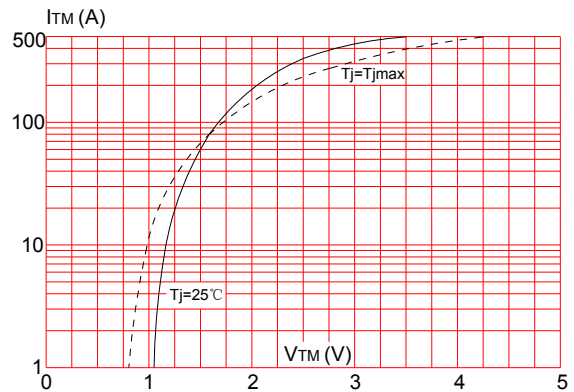

**FIG.6:** Relative variations of gate trigger current, holding current and latching current versus junction temperature

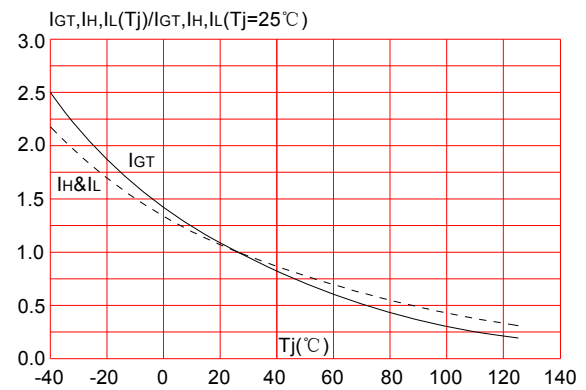

**ORDERING INFORMATION**

Order code	Voltage $V_{DRM}/V_{RRM}$ (V)	IGT(mA)	Package	Base qty. (pcs)	Delivery mode
JCT1240A	1200	45	TO-220A(Ins)	50	Tube
JCT1240C			TO-220C		

**Document Revision History**

Date	Revision	Changes
Dec. 8, 2021	8	Last update

PACKAGE MECHANICAL DATA

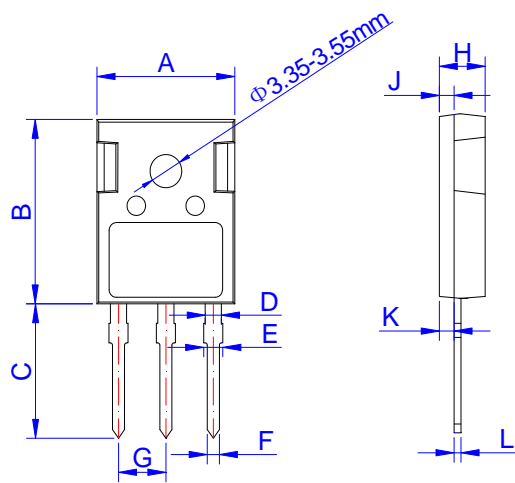

Ref.	Dimensions					
	Millimeters			Inches		
	Min.	Typ.	Max.	Min.	Typ.	Max.
A	15.50	15.80	16.10	0.610	0.622	0.634
B	20.80	21.00	22.20	0.819	0.827	0.835
C	19.70	20.00	20.30	0.776	0.787	0.799
D	1.80	2.00	2.20	0.071	0.079	0.087
E	1.90	2.10	2.30	0.075	0.083	0.091
F	1.00	1.20	1.40	0.039	0.047	0.055
G		5.44			0.214	
H	4.80	5.00	5.20	0.189	0.197	0.205
J	1.90	2.00	2.10	0.075	0.079	0.083
K	2.20	2.35	2.50	0.087	0.093	0.098
L	0.41	0.60	0.79	0.016	0.024	0.031

DELIVERY MODE

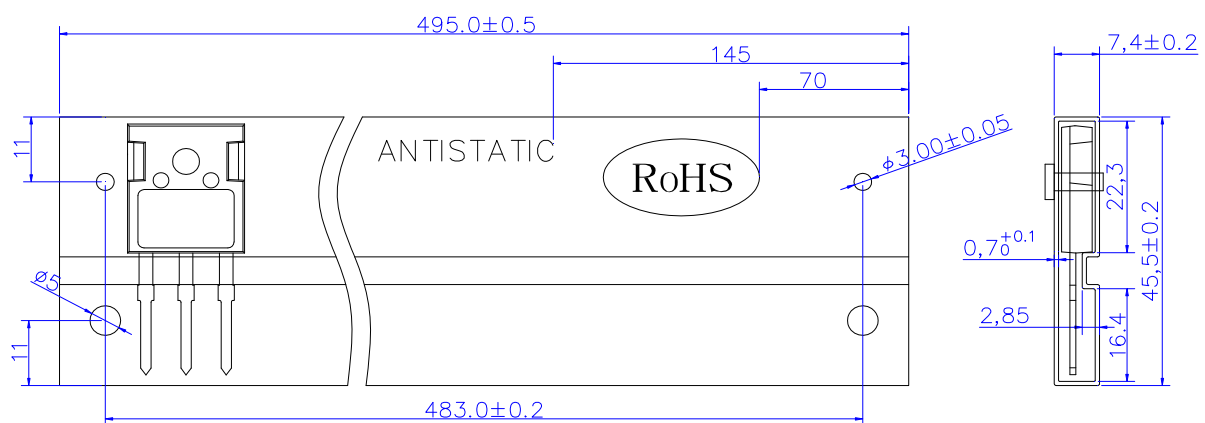

PACKAGE	OUTLINE	TUBE (PCS)	INNER BOX (PCS)	PER CARTON
TO-247J	TUBE	30	450	2,250

**PACKAGE MECHANICAL DATA**

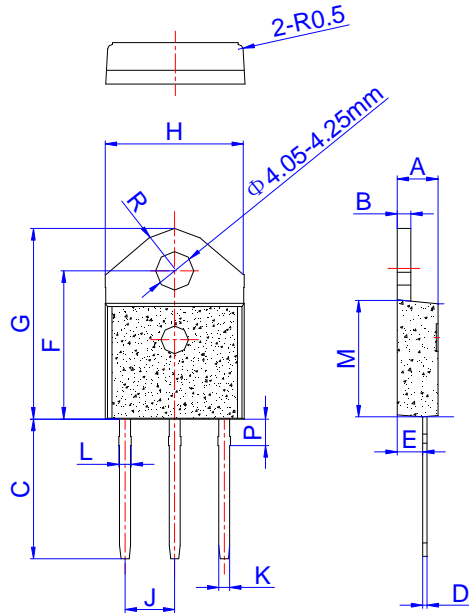

Ref.	Dimensions					
	Millimeters			Inches		
	Min.	Typ.	Max.	Min.	Typ.	Max.
A	4.40		4.60	0.173		0.181
B	1.45		1.55	0.057		0.061
C	14.35		15.60	0.565		0.614
D	0.50		0.70	0.020		0.028
E	2.70		2.90	0.106		0.114
F	15.80		16.50	0.622		0.650
G	20.40		21.10	0.803		0.831
H	15.10		15.50	0.594		0.610
J	5.40		5.65	0.213		0.222
K	1.10		1.40	0.043		0.055
L	1.25		1.45	0.049		0.057
M	12.37		12.77	0.487		0.503
P	2.80		3.00	0.110		0.118
R		4.35			0.171	

**DELIVERY MODE**

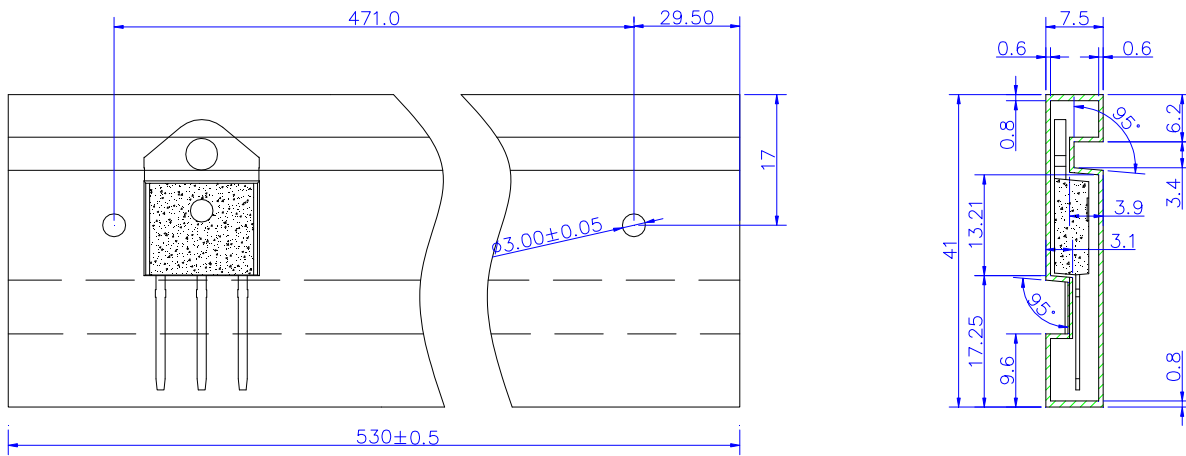

PACKAGE	OUTLINE	TUBE (PCS)	INNER BOX (PCS)	PER CARTON
TO-3P	TUBE	30	450	2,250



Information furnished in this document is believed to be accurate and reliable. However, Jiangsu JieJie Microelectronics Co.,Ltd assumes no responsibility for the consequences of use without consideration for such information nor use beyond it. Information mentioned in this document is subject to change without notice, apart from that when an agreement is signed, Jiangsu JieJie complies with the agreement. Products and information provided in this document have no infringement of patents. Jiangsu JieJie assumes no responsibility for any infringement of other rights of third parties which may result from the use of such products and information. This document supersedes and replaces all information previously supplied.



is a registered trademark of Jiangsu JieJie Microelectronics Co.,Ltd.  
Copyright ©2021 Jiangsu JieJie Microelectronics Co.,Ltd. Printed All rights reserved.