



DESCRIPTION:

The JX008 SCR series provide high dv/dt rate with strong resistance to electromagnetic interface. They are especially recommended for use on residual current circuit breaker, straight hair, igniter etc. All the packages mentioned are RoHS compliant. (2011/65/EU)

MAIN FEATURES

Symbol	Value	Unit
$I_{T(RMS)}$	0.8	A
I_{GT}	≤ 200	μA

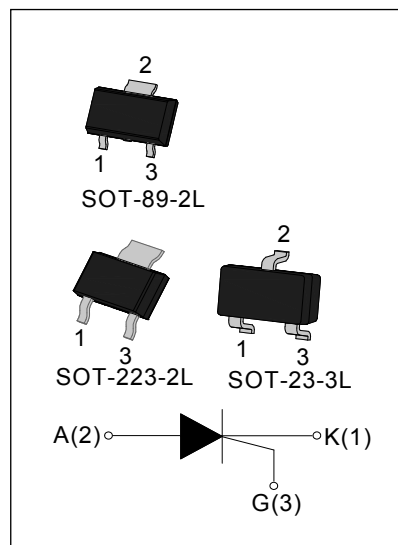

ABSOLUTE MAXIMUM RATINGS

Parameter		Symbol	Value	Unit
Storage junction temperature range		T_{stg}	-40-150	$^{\circ}C$
Operating junction temperature range		T_j	-40-125 ^①	$^{\circ}C$
Repetitive peak off-state voltage		V_{DRM}	600	V
Repetitive peak reverse voltage		V_{RRM}	600	V
RMS on-state current	SOT-23-3L ($T_c=40^{\circ}C$)	$I_{T(RMS)}$	0.8	A
	SOT-89-2L ($T_c=70^{\circ}C$)			
	SOT-223-2L ($T_c=90^{\circ}C$)			
Non repetitive surge peak on-state current (F=50Hz $t_p=10ms$)		I_{TSM}	8	A
Non repetitive surge peak on-state current (F=60Hz $t_p=8.3ms$)		I_{TSM}	9	A
I^2t value for fusing ($t_p=10ms$)		I^2t	0.32	A^2s
Critical rate of rise of on-state current		di/dt	50	$A/\mu s$
Peak gate current ($t_p=20\mu s$, $T_j=125^{\circ}C$)		I_{GM}	0.2	A
Peak gate power ($t_p=20\mu s$, $T_j=125^{\circ}C$)		P_{GM}	0.5	W
Average gate power dissipation ($T_j=125^{\circ}C$)		$P_{G(AV)}$	0.1	W

NOTE 1: When we parallel connect a $\leq 1K\Omega$ resistor between Gate and Cathode, the T_j can reach $125^{\circ}C$; if without this resistor, the T_j only can reach $110^{\circ}C$.

ELECTRICAL CHARACTERISTICS ($T_j=25^{\circ}\text{C}$ unless otherwise specified)

Symbol	Test Condition	Value			Unit
		MIN.	TYP.	MAX.	
I_{GT}	$V_D=12\text{V } R_L=33\Omega$	20	50	200	μA
V_{GT}		-	0.6	0.8	V
V_{GD}	$V_D=V_{DRM} T_j=125^{\circ}\text{C}$	0.2	-	-	V
I_L	$I_G=1.2 I_{GT}$	-	-	4	mA
I_H	$I_T=0.05\text{A}$	-	-	3	mA
dV/dt	$V_D=400\text{V } T_j=125^{\circ}\text{C } R_{GK}=1\text{K}\Omega$	600	-	-	V/ μs
dV/dt	$V_D=400\text{V } T_j=125^{\circ}\text{C } R_{GK}=220\Omega$	1000	-	-	V/ μs
t_{on}	$I_G=10\text{mA } I_A=4\text{mA } I_R=0.4\text{mA}$ $T_j=25^{\circ}\text{C}$	-	2	-	μs
t_{off}		-	50	-	μs

STATIC CHARACTERISTICS

Symbol	Parameter		Value(MAX)	Unit
V_{TM}	$I_T=1.1\text{A } t_p=380\mu\text{s}$	$T_j=25^{\circ}\text{C}$	1.5	V
V_{TO}	Threshold voltage	$T_j=125^{\circ}\text{C}$	1.0	V
V_d	Dynamic Resistance	$T_j=125^{\circ}\text{C}$	500	m Ω
I_{DRM}	$V_D=V_{DRM} V_R=V_{RRM}$	$T_j=25^{\circ}\text{C}$	5	μA
I_{RRM}		$T_j=125^{\circ}\text{C}$	100	μA

THERMAL RESISTANCES

Symbol	Parameter		Value	Unit
$R_{th(j-c)}$	junction to case	SOT-23-3L	75	$^{\circ}\text{C/W}$
		SOT-89-2L	45	
		SOT-223-2L	31	
$R_{th(j-a)}$	junction to ambient	SOT-23-3L	125	$^{\circ}\text{C/W}$
		SOT-89-2L	90	
		SOT-223-2L	60	

ORDERING INFORMATION

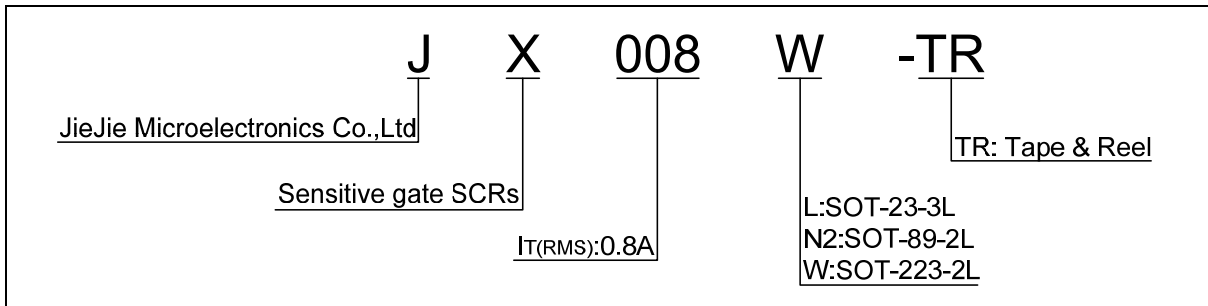

MARKING

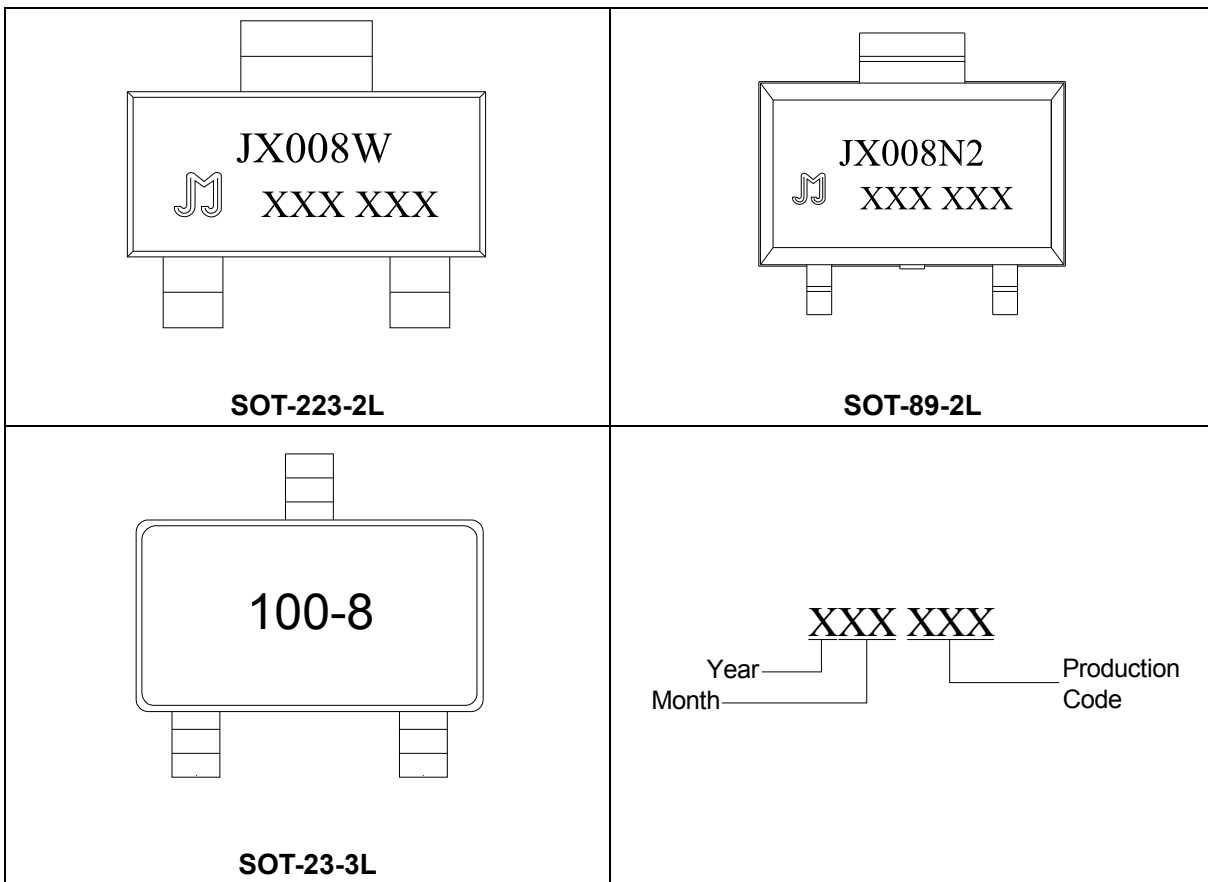

FIG.1 Maximum power dissipation versus RMS on-state current

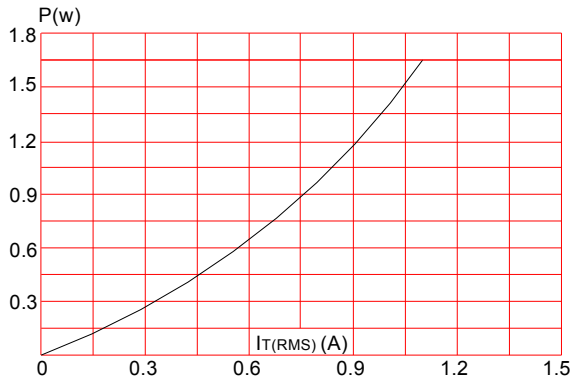

FIG.2: RMS on-state current versus ambient temperature (printed circuit board FR4, copper thickness:35μm)(full cycle)

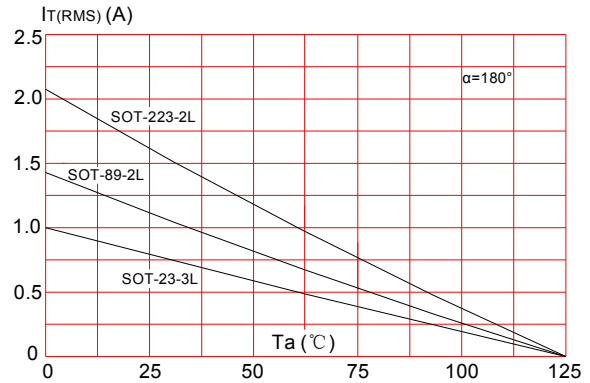

FIG.3: Surge peak on-state current versus number of cycles

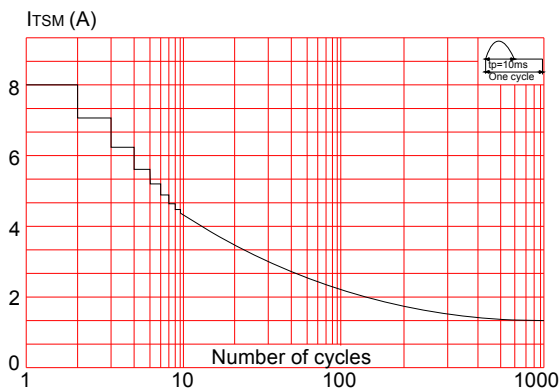

FIG.4: On-state characteristics (maximum values)

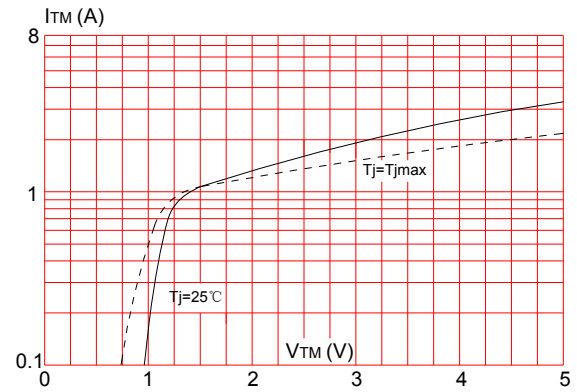

FIG.5: Non-repetitive surge peak on-state current for a sinusoidal pulse with width $t_p < 10\text{ms}$, and corresponding value of I^2t ($di/dt < 50\text{A}/\mu\text{s}$)

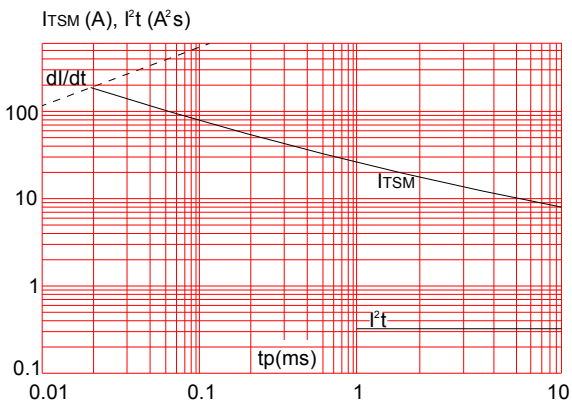
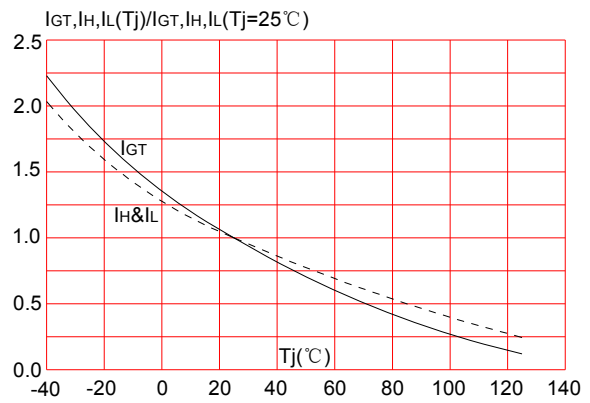
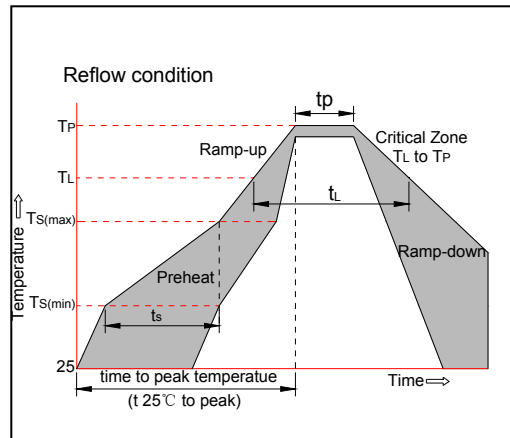

FIG.6: Relative variations of gate trigger current, holding current and latching current versus junction temperature



SOLDERING PARAMETERS

Reflow Condition		Pb-Free assembly (see figure at right)
Pre Heat	-Temperature Min ($T_{s(min)}$)	+150°C
	-Temperature Max ($T_{s(max)}$)	+200°C
	-Time (Min to Max) (t_s)	60-180 secs.
Average ramp up rate (Liquidus Temp (T_L) to peak)		3°C/sec. Max
$T_{s(max)}$ to T_L - Ramp-up Rate		3°C/sec. Max
Reflow	-Temperature(T_L) (Liquidus)	+217°C
	-Temperature(t_L)	60-150 secs.
Peak Temp (T_P)		+260(+0/-5)°C
Time within 5°C of actual Peak Temp (t_p)		20-40secs.
Ramp-down Rate		6°C/sec. Max
Time 25°C to Peak Temp (T_P)		8 min. Max
Do not exceed		+260°C



ORDERING INFORMATION

Order code	Voltage V_{DRM}/V_{RRM} (V)	IGT(μA)	Package	Base qty. (pcs)	Delivery mode
JX008W	600	200	SOT-223-2L	4,000	Tape & Reel
JX008N2			SOT-89-2L	4,000	
JX008L			SOT-23-3L	3,000	

Document Revision History

Date	Revision	Changes
May 29, 2021	10	Last update
July 24, 2021	11	Renew VTO &Rd

PACKAGE MECHANICAL DATA

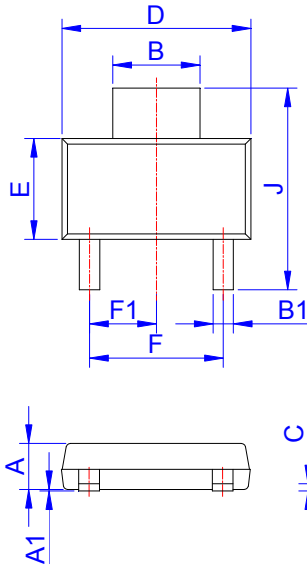

Ref.	Dimensions					
	Millimeters			Inches		
	Min.	Typ.	Max.	Min.	Typ.	Max.
A	1.50	1.60	1.80	0.059	0.063	0.071
A1	0.01	0.06	0.10	0.001	0.002	0.004
B	2.90	3.00	3.10	0.114	0.118	0.122
B1	0.60	0.70	0.80	0.024	0.028	0.031
C	0.22	0.254	0.32	0.009	0.010	0.013
D	6.30	6.50	6.70	0.248	0.256	0.264
E	3.30	3.50	3.70	0.130	0.138	0.146
F		4.60			0.181	
F1		2.30			0.091	
G	0.70	0.90	1.10	0.028	0.035	0.043
H	1.50	1.75	2.00	0.059	0.069	0.079
J	6.70	7.00	7.30	0.264	0.276	0.287
K		0.90			0.035	

FOOTPRINT-SOT-223-2L (dimensions in mm)

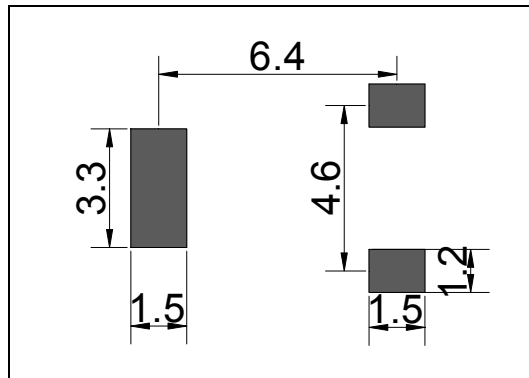

DELIVERY MODE

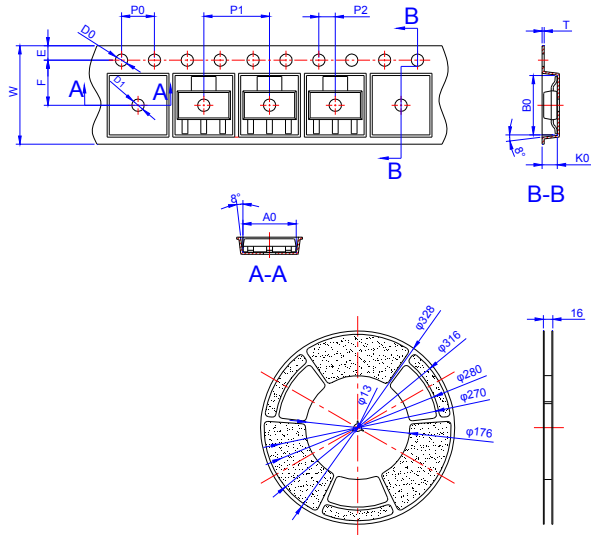

Ref.	Dimensions					
	Millimeters			Inches		
	Min.	Typ.	Max.	Min.	Typ.	Max.
W	-	12.00	12.20	-	0.472	0.480
E	1.65	1.75	1.85	0.065	0.069	0.073
F	5.45	5.50	5.55	0.215	0.217	0.219
D0	-	1.50	1.60	-	0.059	0.063
D1	-	1.55	1.80	-	0.061	0.071
P0	3.90	4.00	4.10	0.154	0.157	0.161
P1	7.90	8.00	8.10	0.311	0.315	0.319
P2	1.95	2.00	2.05	0.077	0.079	0.081
10P0	39.80	40.00	40.20	1.567	1.575	1.583
A0	6.73	6.83	6.93	0.265	0.269	0.273
B0	7.30	7.40	7.50	0.287	0.291	0.295
K0	1.78	1.88	1.98	0.070	0.074	0.078
T	0.25	0.30	0.35	0.010	0.012	0.014

PACKAGE	OUTLINE	REEL (PCS)	PER CARTON (PCS)	TAPE & REEL
SOT-223-2L	TAPING	4,000	40,000	13 inch

PACKAGE MECHANICAL DATA

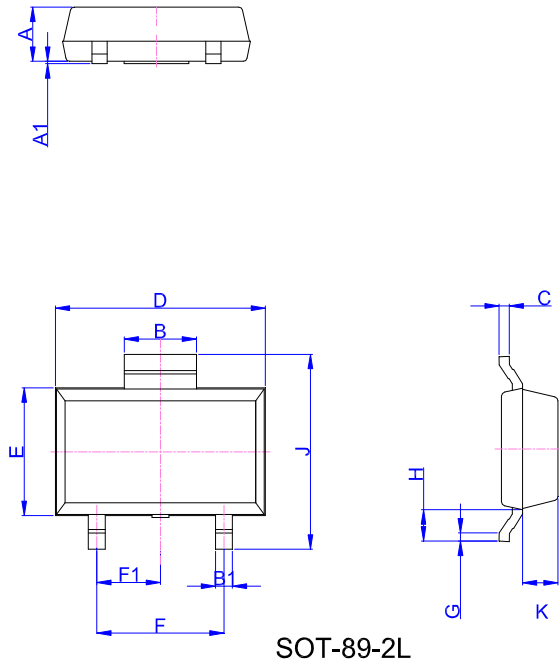

Ref.	Dimensions					
	Millimeters			Inches		
	Min.	Typ.	Max.	Min.	Typ.	Max.
A	1.3	1.4	1.5	0.051	0.055	0.059
A1	0.01	0.06	0.10	0.001	0.002	0.004
B	1.6	1.7	1.8	0.063	0.067	0.071
B1	0.3	0.4	0.5	0.012	0.016	0.020
C	0.22	0.254	0.32	0.009	0.010	0.013
D	4.75	4.95	5.15	0.187	0.195	0.203
E	2.75	2.95	3.15	0.108	0.116	0.124
F		3.0			0.118	
F1		1.5			0.059	
G	0.2	0.3	0.4	0.008	0.012	0.016
H	0.58	0.78	0.98	0.023	0.031	0.039
J	4.3	4.5	4.7	0.169	0.177	0.185
K		0.88			0.035	

FOOTPRINT-SOT-89-2L (dimensions in mm)

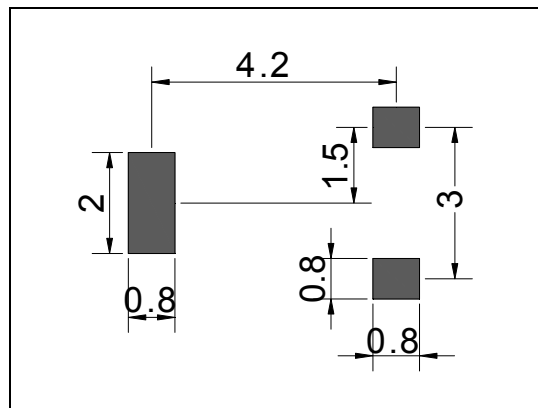

DELIVERY MODE

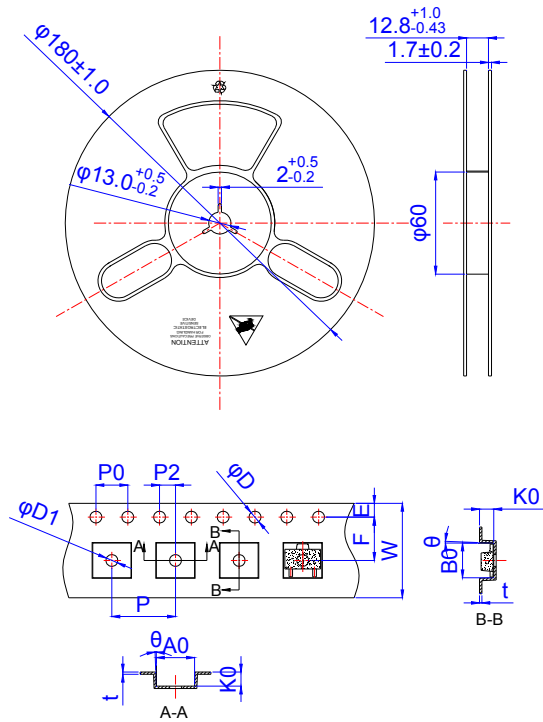

Ref.	Dimensions					
	Millimeters			Inches		
	Min.	Typ.	Max.	Min.	Typ.	Max.
E	1.65	1.75	1.85	0.065	0.069	0.073
F	5.45	5.50	5.55	0.215	0.217	0.219
P2	1.95	2.00	2.05	0.077	0.079	0.081
D	-	1.50	1.60	-	0.059	0.063
D1	1.40	1.50	1.60	0.055	0.059	0.063
P0	3.90	4.00	4.10	0.154	0.157	0.161
10P0	39.80	40.00	40.20	1.567	1.575	1.583
W	11.90	12.00	12.10	0.469	0.472	0.476
P	7.90	8.00	8.10	0.311	0.315	0.319
A0	4.70	4.80	4.90	0.185	0.189	0.193
B0	4.30	4.40	4.50	0.169	0.173	0.177
K0	1.70	1.80	1.90	0.067	0.071	0.075
t	0.25	0.30	0.35	0.010	0.012	0.014
θ	3°		5°	3°		5°

PACKAGE	OUTLINE	REEL (PCS)	PER CARTON (PCS)	TAPE & REEL
SOT-89-2L	TAPING	4,000	40,000	13 inch

PACKAGE MECHANICAL DATA

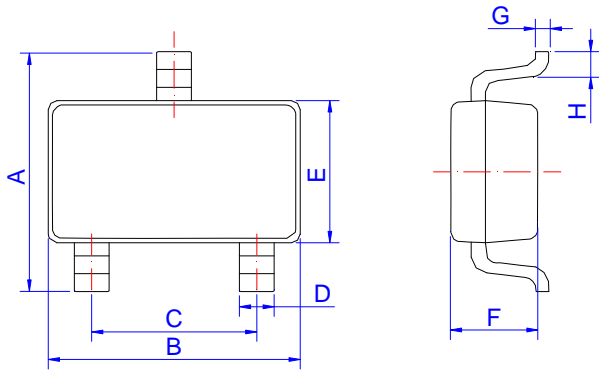

SOT-23-3L

Ref.	Dimensions					
	Millimeters			Inches		
	Min.	Typ.	Max.	Min.	Typ.	Max.
A	2.65	2.80	2.95	0.104	0.110	0.116
B	2.82	2.92	3.02	0.111	0.115	0.119
C	1.80	1.90	2.00	0.071	0.075	0.079
D	0.30	0.35	0.50	0.012	0.014	0.020
E	1.50	1.60	1.70	0.059	0.063	0.067
F	1.07	1.17	1.27	0.042	0.046	0.050
G	0.05	0.15	0.25	0.002	0.006	0.010
H	0.25	0.40	0.55	0.010	0.016	0.022

FOOTPRINT-SOT-23-3L (dimensions in mm)

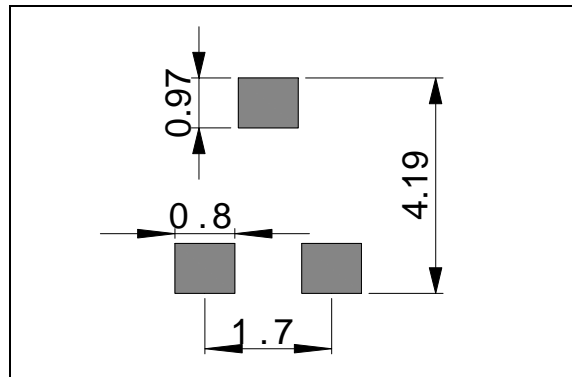

DELIVERY MODE

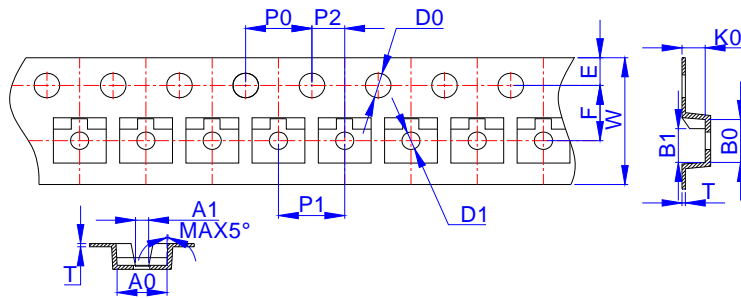

Ref.	Dimensions					
	Millimeters			Inches		
	Min.	Typ.	Max.	Min.	Typ.	Max.
A0	3.10	3.20	3.30	0.122	0.126	0.130
A1	1.02	1.04	1.06	0.040	0.041	0.042
B0	3.18	3.28	3.38	0.125	0.129	0.133
B1	2.39	2.49	2.59	0.094	0.098	0.102
K0	1.22	1.32	1.42	0.048	0.052	0.056
P0	3.90	4.00	4.10	0.154	0.157	0.161
P1	3.90	4.00	4.10	0.154	0.157	0.161
P2	1.95	2.00	2.05	0.077	0.079	0.081
T	0.15	0.20	0.25	0.006	0.008	0.010
E	1.65	1.75	1.85	0.065	0.069	0.073
F	3.45	3.50	3.55	0.136	0.138	0.140
D0	1.50	1.55	1.60	0.059	0.061	0.063
D1	1.00	1.10	1.20	0.039	0.043	0.047
W	7.90	8.00	8.20	0.311	0.315	0.323

PACKAGE	OUTLINE	REEL (PCS)	PER CARTON (PCS)	TAPE & REEL
SOT-23-3L	TAPING	3,000	120,000	7 inch



Information furnished in this document is believed to be accurate and reliable. However, Jiangsu JieJie Microelectronics Co.,Ltd assumes no responsibility for the consequences of use without consideration for such information nor use beyond it. Information mentioned in this document is subject to change without notice, apart from that when an agreement is signed, Jiangsu JieJie complies with the agreement. Products and information provided in this document have no infringement of patents. Jiangsu JieJie assumes no responsibility for any infringement of other rights of third parties which may result from the use of such products and information. This document supersedes and replaces all information previously supplied.

 is a registered trademark of Jiangsu JieJie Microelectronics Co.,Ltd.

Copyright ©2021 Jiangsu JieJie Microelectronics Co.,Ltd. Printed All rights reserved.