



## T08xxH Series 8A TRIACs

Rev.8.0

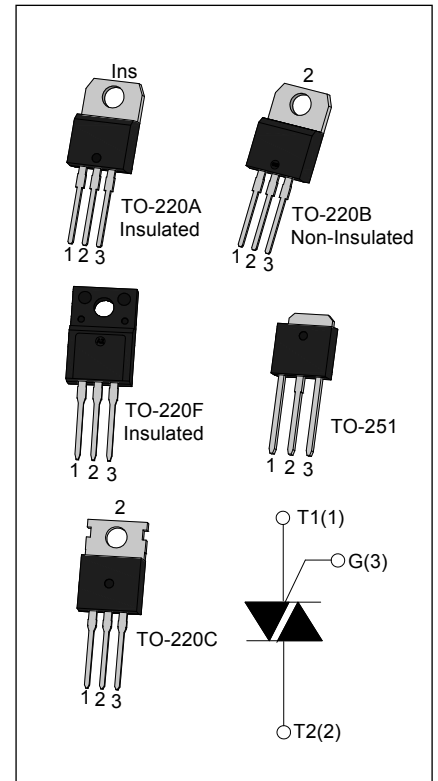
### DESCRIPTION:

T08xxH series triacs of high junction temperature with high dv/dt rate with strong resistance to electromagnetic interference provide high ability to withstand the shock loading of large current. They are especially recommended for use on inductive load and high environment temperature condition.

From all three terminals to external heatsink, T08xxH-xxA provides a rated insulation voltage of 2500 V<sub>RMS</sub>, and T08xxH-xxF provides a rated insulation voltage of 2000 V<sub>RMS</sub>, complying with UL standards (File ref: E252906). All the packages listed above are RoHS compliant. (2011/65/EU)

### MAIN FEATURES

Symbol	Value	Unit
I <sub>T(RMS)</sub>	8	A
V <sub>DRM</sub> /V <sub>RPM</sub>	600/800	V



### ABSOLUTE MAXIMUM RATINGS

Parameter	Symbol	Value	Unit
Storage junction temperature range	T <sub>stg</sub>	-40-150	°C
Operating junction temperature range	T <sub>j</sub>	-40-150	°C
Repetitive peak off-state voltage(T <sub>j</sub> =25°C)	V <sub>DRM</sub>	600/800	V
Repetitive peak reverse voltage(T <sub>j</sub> =25°C)	V <sub>RPM</sub>	600/800	V
RMS on-state current	TO-220A(Ins)/ TO-220F(Ins) (T <sub>c</sub> =115°C)	8	A
	TO-251 (T <sub>c</sub> =120°C)		
	TO-220B(Non-Ins)/ TO-220C (T <sub>c</sub> =125°C)		
Non repetitive surge peak on-state current (full cycle, F=50Hz)	I <sub>TSM</sub>	80	A
I <sup>2</sup> t value for fusing (t <sub>p</sub> =10ms)	I <sup>2</sup> t	36	A <sup>2</sup> s
Critical rate of rise of on-state current (I <sub>G</sub> =2×I <sub>GT</sub> )	di/dt	50	A/μs

Peak gate current	$I_{GM}$	4	A
Average gate power dissipation	$P_{G(AV)}$	1	W
Peak gate power	$P_{GM}$	5	W

**ELECTRICAL CHARACTERISTICS** ( $T_j=25^\circ\text{C}$  unless otherwise specified)

Symbol	Test Condition	Quadrant		Value				Unit
				T0810H	T0820H	T0835H	T0850H	
$I_{GT}$	$V_D=12\text{V } R_L=33\Omega$	I - II - III	MAX	10	20	35	50	mA
$V_{GT}$		I - II - III	MAX	1.3				V
$V_{GD}$	$V_D=V_{DRM} T_j=150^\circ\text{C}$ $R_L=3.3\text{K}\Omega$	I - II - III	MIN	0.2				V
$I_L$	$I_G=1.2I_{GT}$	I - III	MAX	20	40	50	70	mA
		II		35	55	70	80	
$I_H$	$I_T=100\text{mA}$		MAX	20	30	45	60	mA
dV/dt	$V_D=2/3V_{DRM} R_{GK}=1\text{K}\Omega T_j=150^\circ\text{C}$		MIN	200	500	1000	1500	V/ $\mu\text{s}$

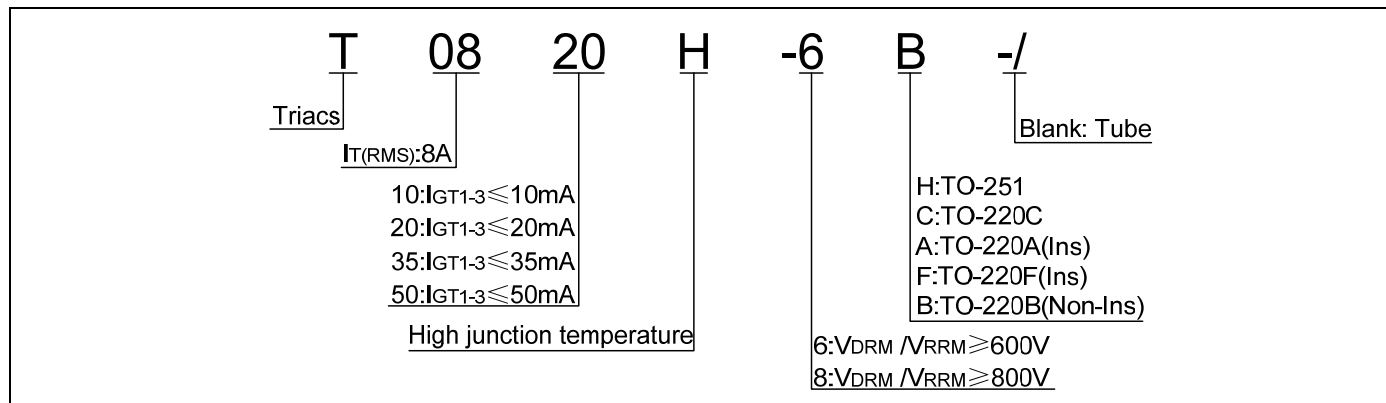
**STATIC CHARACTERISTICS**

Symbol	Parameter		Value(MAX)	Unit
$V_{TM}$	$I_{TM}=11\text{A } t_p=380\mu\text{s}$	$T_j=25^\circ\text{C}$	1.4	V
$V_{TO}$	Threshold voltage	$T_j=150^\circ\text{C}$	0.95	V
$R_d$	Dynamic resistance	$T_j=150^\circ\text{C}$	35	m $\Omega$
$I_{DRM}$	$V_D=V_{DRM} V_R=V_{RRM}$	$T_j=25^\circ\text{C}$	5	$\mu\text{A}$
$I_{RRM}$		$T_j=150^\circ\text{C}$	1.5	mA

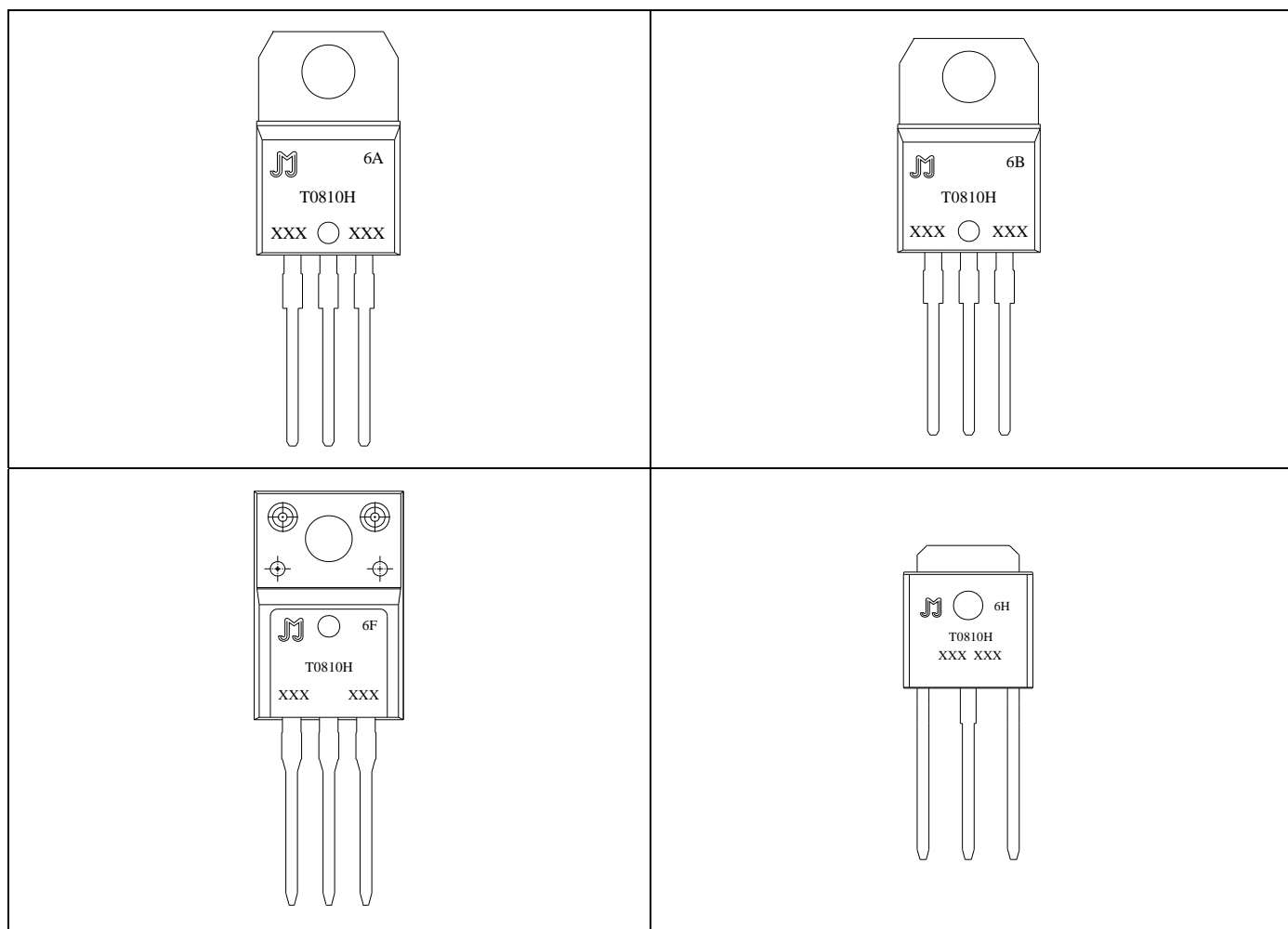
**THERMAL RESISTANCES**

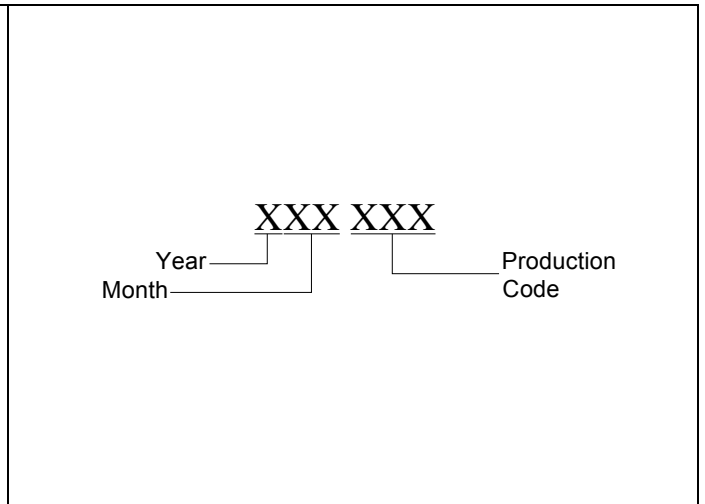
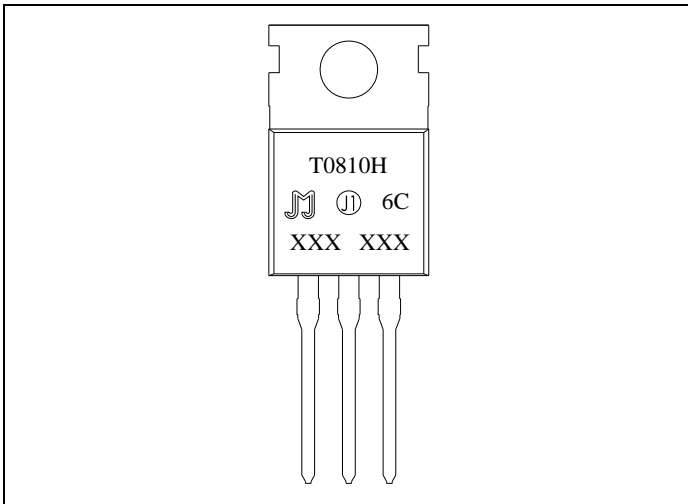
Symbol	Parameter		Value	Unit
$R_{th(j-c)}$	junction to case(AC)	TO-220A(Ins)	2.5	$^\circ\text{C/W}$
		TO-251	2.0	
		TO-220B(Non-Ins)/ TO-220C	1.6	
		TO-220F(Ins)	2.6	

ORDERING INFORMATION

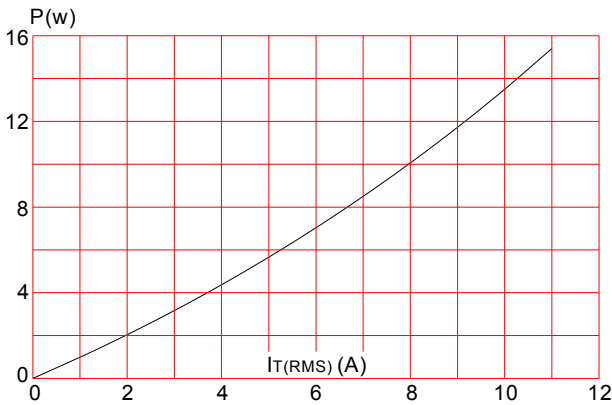


MARKING

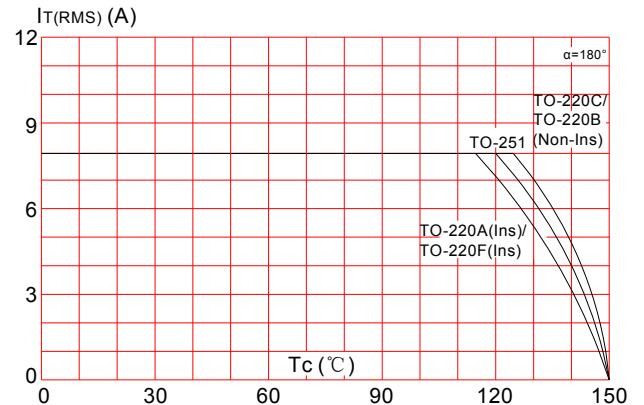




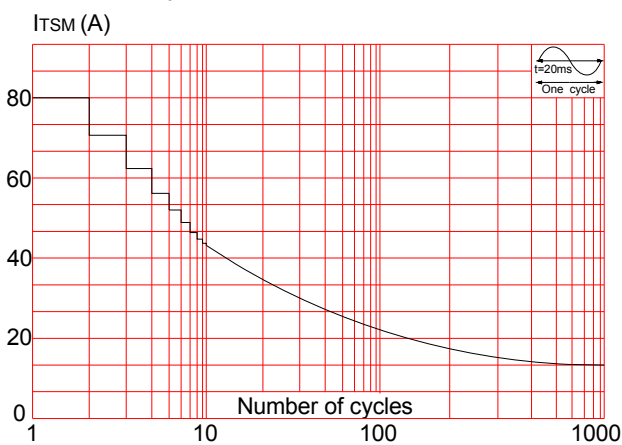
**FIG.1:** Maximum power dissipation versus RMS on-state current



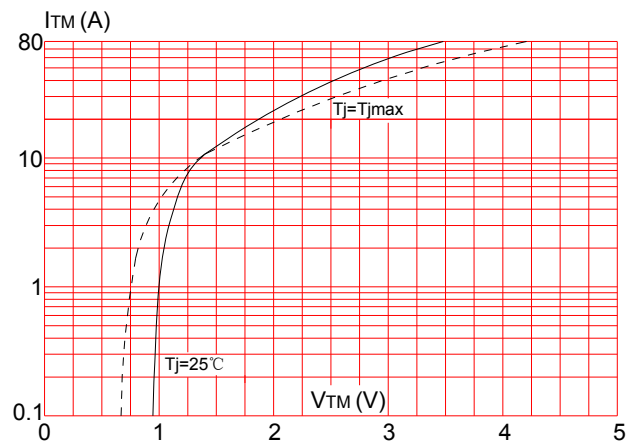
**FIG.2:** RMS on-state current versus case temperature



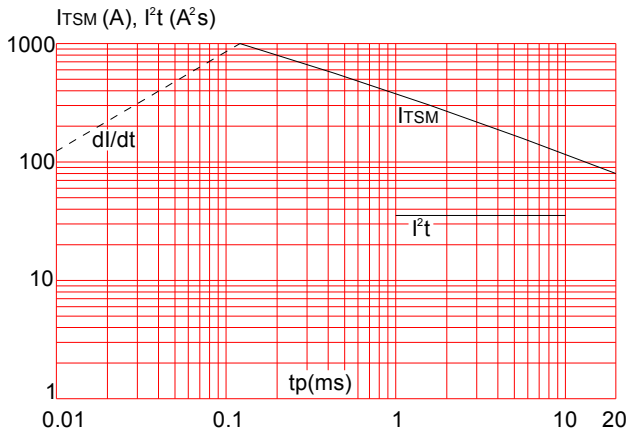
**FIG.3:** Surge peak on-state current versus number of cycles



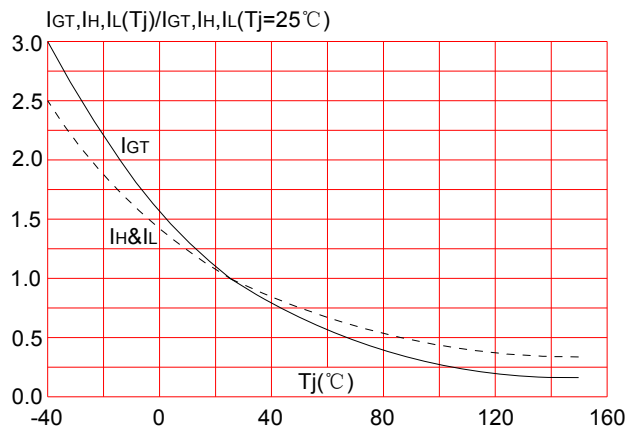
**FIG.4:** On-state characteristics (maximum values)



**FIG.5:** Non-repetitive surge peak on-state current for a sinusoidal pulse with width  $t_p < 20\text{ms}$ , and corresponding value of  $I^2t$  ( $di/dt < 50\text{A}/\mu\text{s}$ )



**FIG.6:** Relative variations of gate trigger current, holding current and latching current versus junction temperature



## ORDERING INFORMATION

Order code	Voltage $V_{\text{DRM}}/V_{\text{RRM}}$ (V)	IGT(mA)	Package	Base qty. (pcs)	Delivery mode
T0810H-6(8)A	600/800	10	TO-220A(Ins)	50	Tube
T0820H-6(8)A		20			
T0835H-6(8)A		35			
T0850H-6(8)A		50			
T0810H-6(8)B		10	TO-220B		
T0820H-6(8)B		20			
T0835H-6(8)B		35			
T0850H-6(8)B		50			
T0810H-6(8)C		10	TO-220C		
T0820H-6(8)C		20			
T0835H-6(8)C		35			
T0850H-6(8)C		50			
T0810H-6(8)F		10	TO-220F(Ins)		
T0820H-6(8)F		20			
T0835H-6(8)F		35			
T0850H-6(8)F		50			

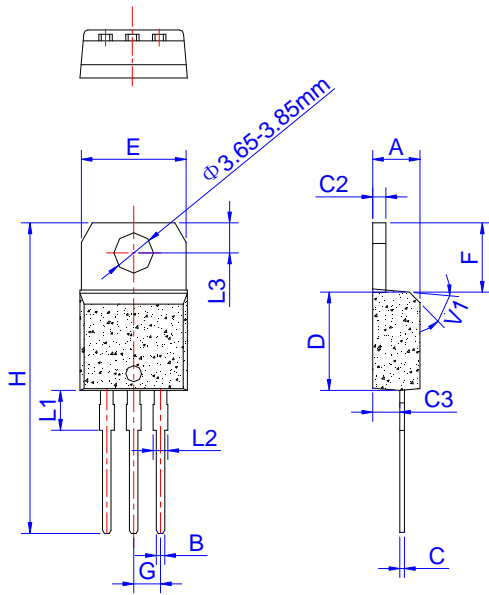
**ORDERING INFORMATION**

<b>T0810H-6(8)H</b>	<b>600/800</b>	<b>10</b>	<b>TO-251</b>	<b>80</b>	<b>Tube</b>
<b>T0820H-6(8)H</b>		<b>20</b>			
<b>T0835H-6(8)H</b>		<b>35</b>			
<b>T0850H-6(8)H</b>		<b>50</b>			

**Document Revision History**

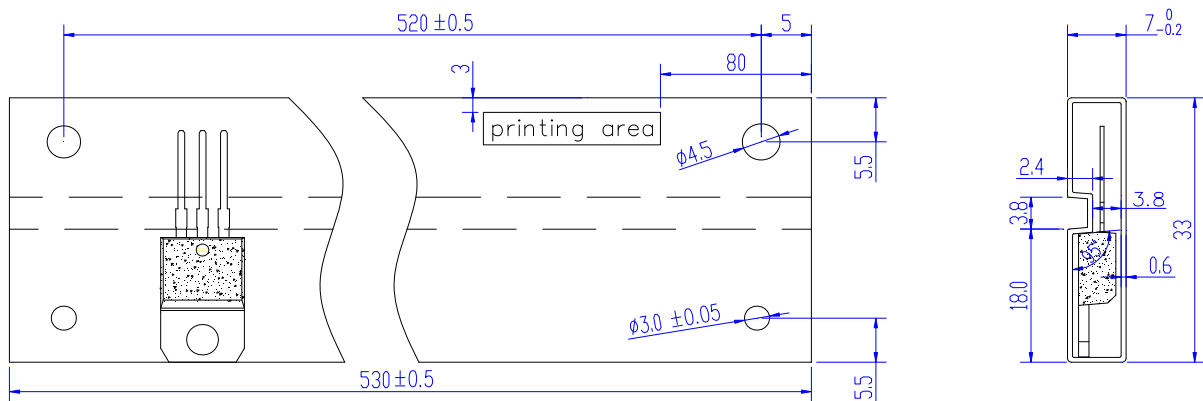
<b>Date</b>	<b>Revision</b>	<b>Changes</b>
Apr 30, 2019	6	Last updated
Oct 20, 2021	7	Add Vto & Rd value
Nov 17, 2021	8	Add Package TO-220C

PACKAGE MECHANICAL DATA



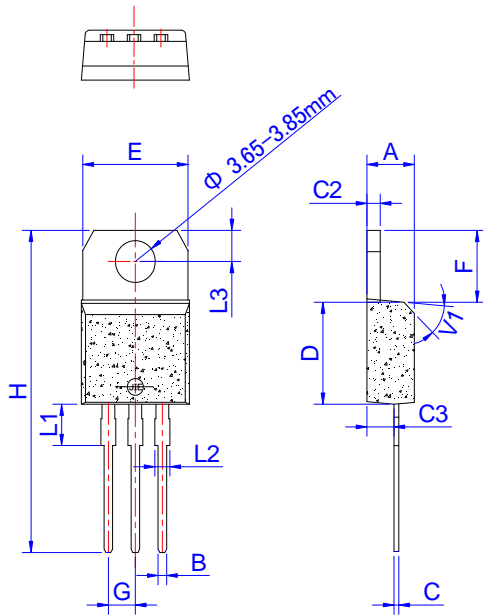
Ref.	Dimensions					
	Millimeters			Inches		
	Min.	Typ.	Max.	Min.	Typ.	Max.
A	4.40		4.60	0.173		0.181
B	0.61		0.88	0.024		0.035
C	0.46		0.70	0.018		0.028
C2	1.21		1.32	0.048		0.052
C3	2.40		2.72	0.094		0.107
D	8.60		9.70	0.339		0.382
E	9.80		10.4	0.386		0.409
F	6.55		6.95	0.258		0.274
G	2.40		2.70	0.094		0.106
H	28.0		29.8	1.102		1.173
L1		3.75			0.148	
L2	1.14		1.70	0.045		0.067
L3	2.65		2.95	0.104		0.116
V1		45°			45°	

DELIVERY MODE



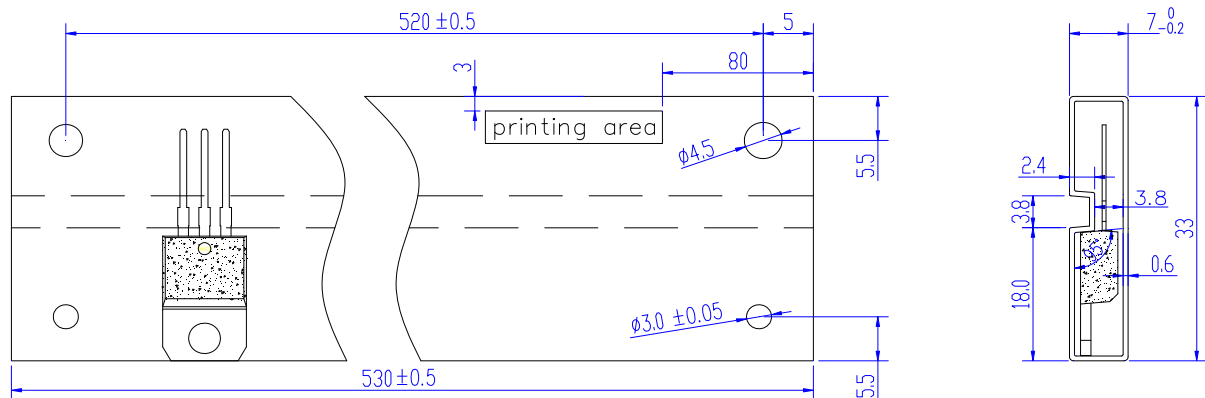
PACKAGE	OUTLINE	TUBE (PCS)	INNER BOX (PCS)	PER CARTON
TO-220A	TUBE	50	1,000	5,000

PACKAGE MECHANICAL DATA



Ref.	Dimensions					
	Millimeters			Inches		
	Min.	Typ.	Max.	Min.	Typ.	Max.
A	4.40		4.60	0.173		0.181
B	0.61		0.88	0.024		0.035
C	0.46		0.70	0.018		0.028
C2	1.21		1.32	0.048		0.052
C3	2.40		2.72	0.094		0.107
D	8.60		9.70	0.339		0.382
E	9.60		10.4	0.378		0.409
F	6.20		6.60	0.244		0.260
G	2.40		2.70	0.094		0.106
H	28.0		29.8	1.102		1.173
L1		3.75			0.147	
L2	1.14		1.70	0.045		0.067
L3	2.65		2.95	0.104		0.116
V1		45°			45°	

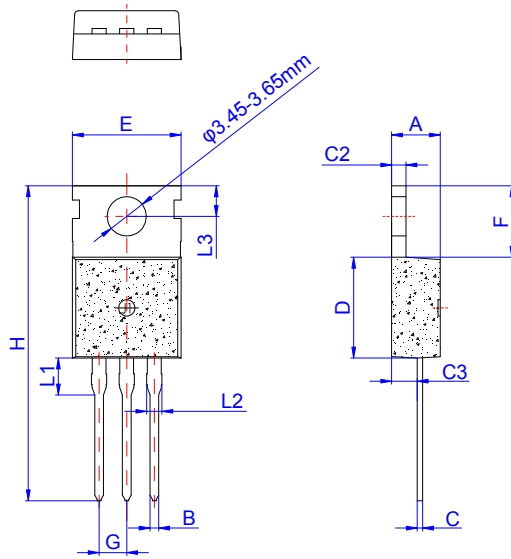
DELIVERY MODE



PACKAGE	OUTLINE	TUBE (PCS)	INNER BOX (PCS)	PER CARTON
TO-220B	TUBE	50	1,000	5,000

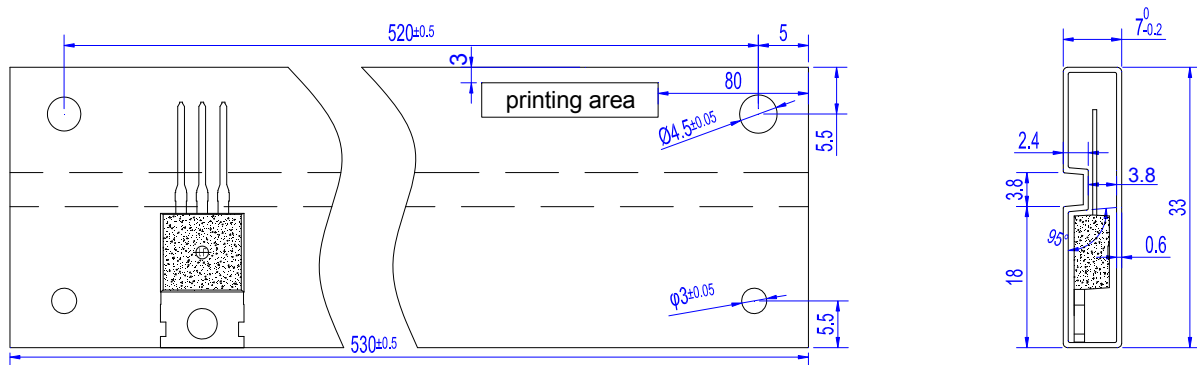


PACKAGE MECHANICAL DATA



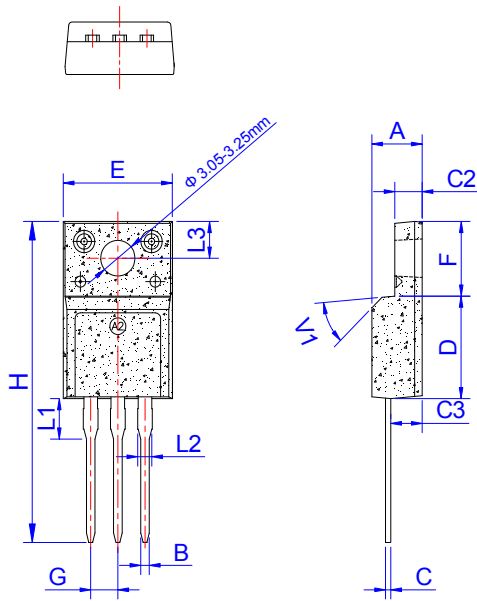
Ref.	Dimensions					
	Millimeters			Inches		
	Min.	Typ.	Max.	Min.	Typ.	Max.
A	4.40		4.60	0.173		0.181
B	0.70		0.90	0.028		0.035
C	0.45		0.60	0.018		0.024
C2	1.23		1.32	0.048		0.052
C3	2.20		2.60	0.087		0.102
D	8.90		9.90	0.350		0.390
E	9.90		10.3	0.390		0.406
F	6.30		6.90	0.248		0.272
G		2.54			0.1	
H	28.0		29.8	1.102		1.173
L1		3.39			0.133	
L2	1.14		1.70	0.045		0.067
L3	2.65		2.95	0.104		0.116

DELIVERY MODE



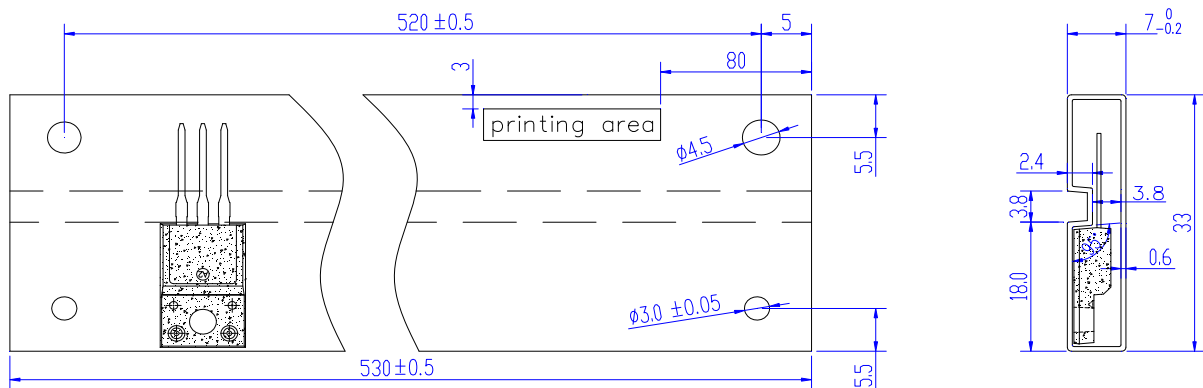
PACKAGE	OUTLINE	TUBE (PCS)	INNER BOX (PCS)	PER CARTON
TO-220C	TUBE	50	1,000	5,000

PACKAGE MECHANICAL DATA



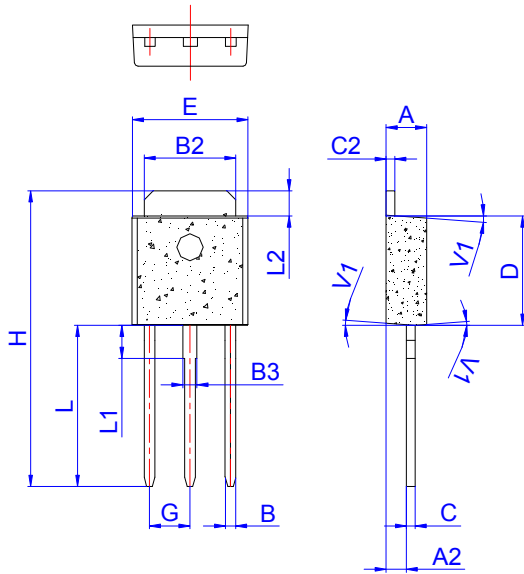
Ref.	Dimensions					
	Millimeters			Inches		
	Min.	Typ.	Max.	Min.	Typ.	Max.
A	4.50		4.90	0.177		0.193
B	0.74	0.80	0.83	0.029	0.031	0.033
C	0.47		0.65	0.019		0.026
C2	2.45		2.75	0.096		0.108
C3	2.60		3.00	0.102		0.118
D	8.80		9.30	0.346		0.366
E	9.80		10.4	0.386		0.410
F	6.40		6.80	0.252		0.268
G	2.40		2.70	0.094		0.106
H	28.0		29.8	1.102		1.173
L1		3.63			0.143	
L2	1.14		1.70	0.045		0.067
L3		3.30			0.130	
V1		45°			45°	

DELIVERY MODE



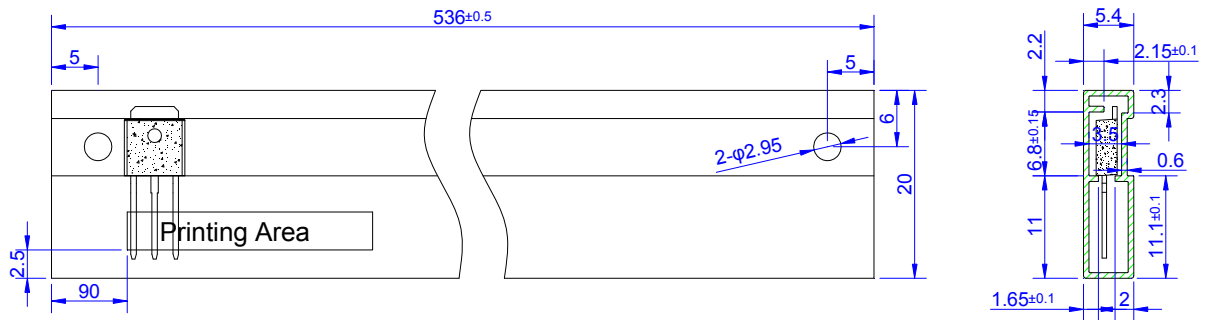
PACKAGE	OUTLINE	TUBE (PCS)	INNER BOX (PCS)	PER CARTON
TO-220F	TUBE	50	1,000	5,000

PACKAGE MECHANICAL DATA



Ref.	Dimensions					
	Millimeters			Inches		
	Min.	Typ.	Max.	Min.	Typ.	Max.
A	2.20		2.40	0.086		0.095
A2	0.90		1.20	0.035		0.047
B	0.55		0.65	0.022		0.026
B2	5.10		5.40	0.200		0.213
B3	0.76		0.85	0.030		0.033
C	0.45		0.62	0.018		0.024
C2	0.48		0.62	0.019		0.024
D	6.00		6.20	0.236		0.244
E	6.40		6.70	0.252		0.264
G		2.30			0.091	
H	16.0		17.0	0.630		0.669
L	8.90		9.40	0.350		0.370
L1	1.80		1.90	0.071		0.075
L2	1.37		1.50	0.054		0.059
V1		4°			4°	

DELIVERY MODE



PACKAGE	OUTLINE	TUBE (PCS)	INNER BOX (PCS)	PER CARTON
TO-251	TUBE	80	4,000	20,000



Information furnished in this document is believed to be accurate and reliable. However, Jiangsu JieJie Microelectronics Co.,Ltd assumes no responsibility for the consequences of use without consideration for such information nor use beyond it. Information mentioned in this document is subject to change without notice, apart from that when an agreement is signed, Jiangsu JieJie complies with the agreement. Products and information provided in this document have no infringement of patents. Jiangsu JieJie assumes no responsibility for any infringement of other rights of third parties which may result from the use of such products and information. This document supersedes and replaces all information previously supplied.



is a registered trademark of Jiangsu JieJie Microelectronics Co.,Ltd.  
Copyright ©2021 Jiangsu JieJie Microelectronics Co.,Ltd. Printed All rights reserved.