



BCR20PM-16L 20A TRIACs

Rev.1

DESCRIPTION:

BCR20PM-16L triacs, with high ability to withstand the shock loading of large current, provide high dv/dt rate with strong resistance to electromagnetic interference. With high commutation performances, 3 quadrants products especially recommended for use on inductive load. From all three terminals to external heatsink, BCR20PM-16L provides a rated insulation voltage of 2000 V_{RMS} , complying with UL standards (File ref: E252906). Package TO-220F is RoHS compliant. (2011/65/EU)

MAIN FEATURES

Symbol	Value	Unit
T_j	150	$^{\circ}C$
$I_{T(RMS)}$	20	A
V_{DRM}/V_{RRM}	800	V

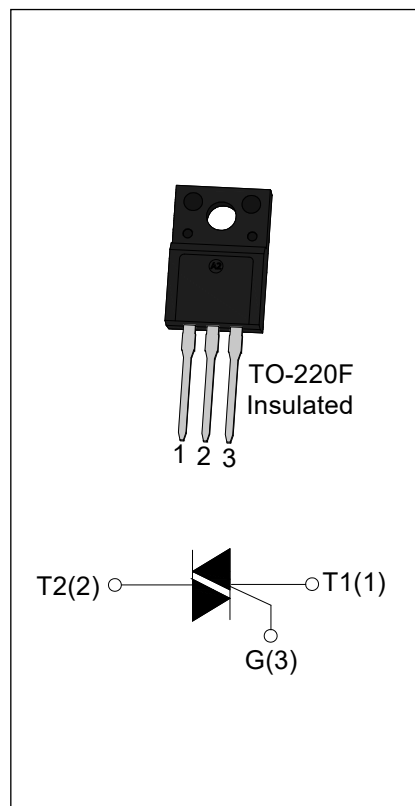

ABSOLUTE MAXIMUM RATINGS

Parameter		Symbol	Value	Unit
Storage junction temperature range		T_{stg}	-40-150	$^{\circ}C$
Operating junction temperature range		T_j	-40-150	$^{\circ}C$
Repetitive peak off-state voltage ($T_j=150^{\circ}C$)		V_{DRM}	700	V
Repetitive peak reverse voltage ($T_j=150^{\circ}C$)		V_{DRM}	700	V
Repetitive peak off-state voltage ($T_j=125^{\circ}C$)		V_{DRM}	800	V
Repetitive peak reverse voltage ($T_j=125^{\circ}C$)		V_{DRM}	800	V
RMS on-state current	TO-220F(Ins) ($T_C=85^{\circ}C$)	$I_{T(RMS)}$	20	A
Non repetitive surge peak on-state current (full cycle, F=50Hz)		I_{TSM}	200	A
I^2t value for fusing ($t_p=10ms$)		I^2t	200	A^2s
Critical rate of rise of on-state current ($I_G=2 \times I_{GT}$)		di/dt	100	$A/\mu s$

Peak gate current	I_{GM}	4	A
Average gate power dissipation	$P_{G(AV)}$	1	W
Peak gate power	P_{GM}	10	W

ELECTRICAL CHARACTERISTICS ($T_j=25^\circ\text{C}$ unless otherwise specified)

Symbol	Test Condition	Quadrant		Value	Unit
I_{GT}	$V_D=12\text{V } R_L=33\Omega$	I - II -III	MAX	35	mA
V_{GT}		I - II -III	MAX	1.3	V
V_{GD}	$V_D=V_{DRM} T_j=150^\circ\text{C}$ $R_L=3.3\text{K}\Omega$	I - II -III	MIN	0.2	V
I_L	$I_G=1.2I_{GT}$	I -III	MAX	60	mA
		II		70	
I_H	$I_T=100\text{mA}$		MAX	50	mA
dV/dt	$V_D=2/3V_{DRM}$ Gate Open $T_j=150^\circ\text{C}$		MIN	500	V/ μs
(dV/dt) _c	(dI/dt) _c =8.8A/ms $T_j=150^\circ\text{C}$		MIN	7	V/ μs

STATIC CHARACTERISTICS

Symbol	Parameter		Value(MAX)	Unit
V_{TM}	$I_{TM}=28\text{A } t_p=380\mu\text{s}$	$T_j=25^\circ\text{C}$	1.55	V
I_{DRM}	$V_D=V_{DRM} V_R=V_{RRM}$	$T_j=25^\circ\text{C}$	5	μA
I_{RRM}		$T_j=150^\circ\text{C}$	2.5	mA

THERMAL RESISTANCES

Symbol	Parameter		Value	Unit
$R_{th(j-c)}$	junction to case(AC)	TO-220F(Ins)	2.1	$^\circ\text{C/W}$

MARKING

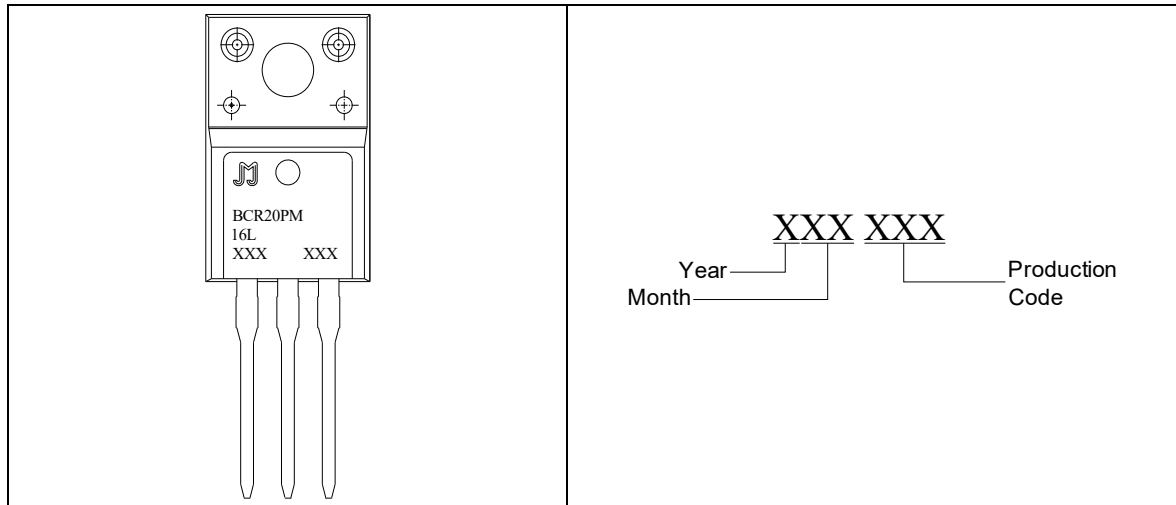

FIG.1: Maximum power dissipation versus RMS on-state current

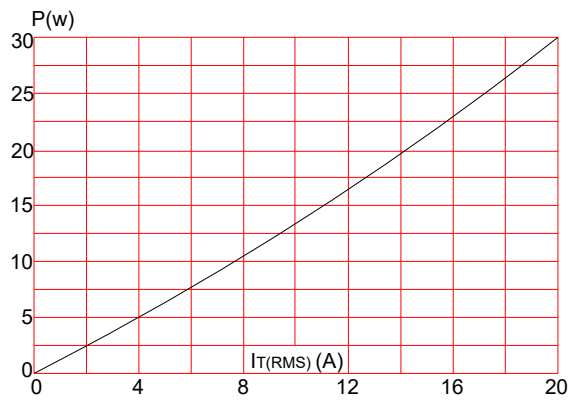

FIG.2: RMS on-state current versus case temperature

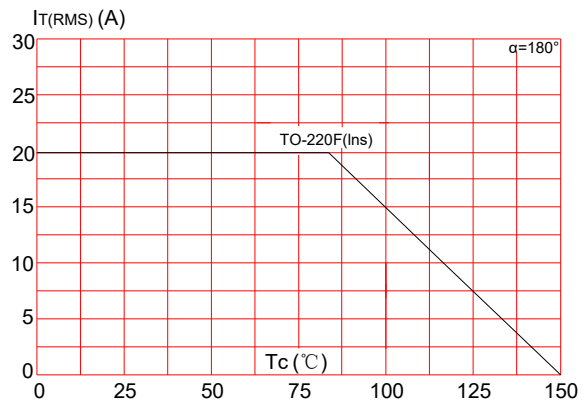

FIG.3: Surge peak on-state current versus number of cycles

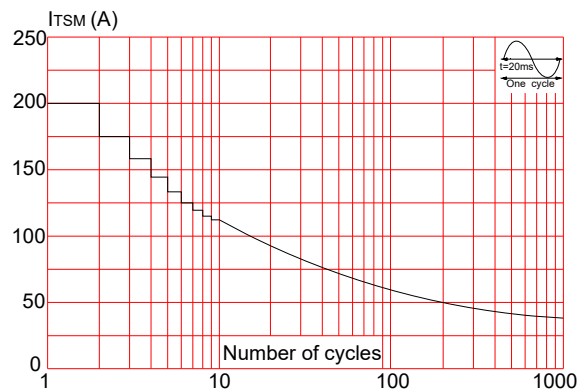

FIG.4: On-state characteristics (maximum values)

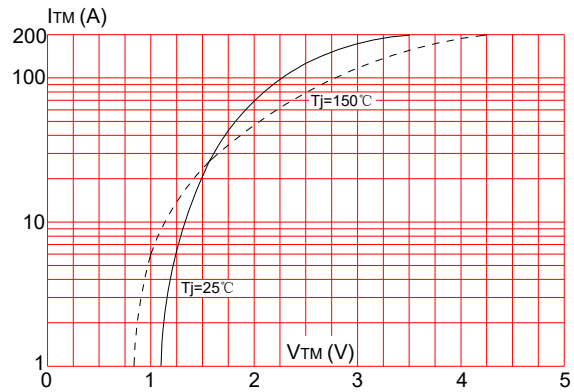

FIG.5: Non-repetitive surge peak on-state current for a sinusoidal pulse with width $t_p < 20\text{ms}$, and corresponding value of I^2t ($dI/dt < 100\text{A}/\mu\text{s}$)

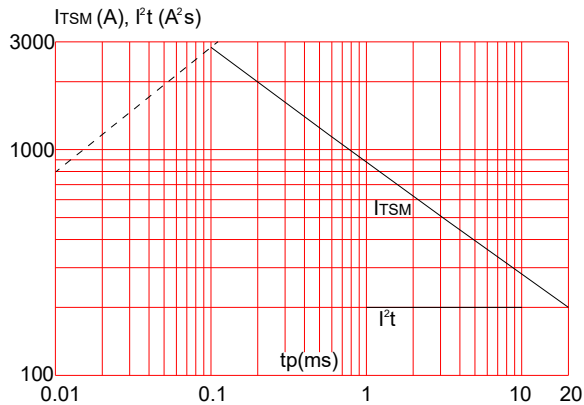
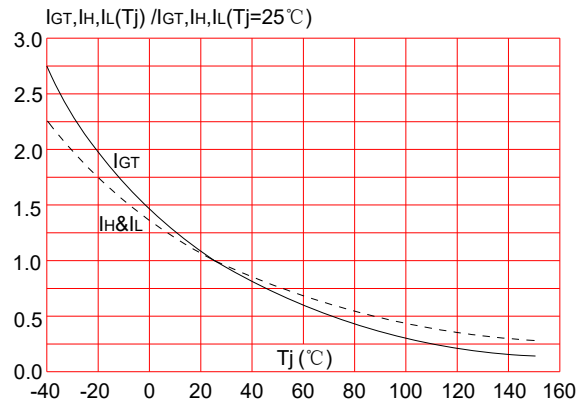

FIG.6: Relative variations of gate trigger current, holding current and latching current versus junction temperature



ORDERING INFORMATION

Order code	Voltage V_{DRM}/V_{RRM} (V)	IGT(mA)	Package	Base qty. (pcs)	Deliver y mode
BCR20PM-16L	800	35	TO-220F(Ins)	50	Tube

Document Revision History

Date	Revision	Changes
Mar 27, 2022	1	Last update

PACKAGE MECHANICAL DATA

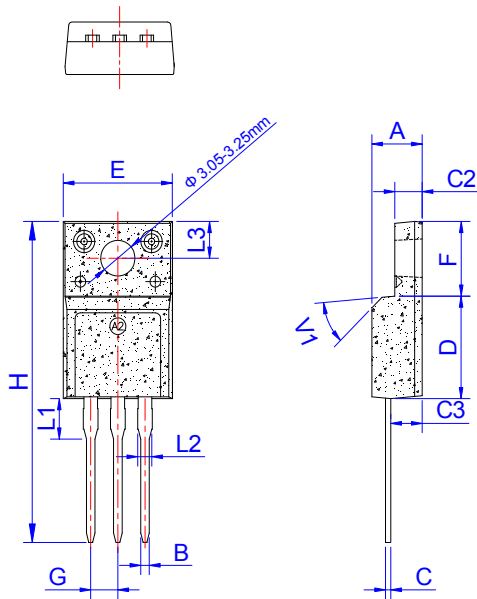

Ref.	Dimensions					
	Millimeters			Inches		
	Min.	Typ.	Max.	Min.	Typ.	Max.
A	4.50		4.90	0.177		0.193
B	0.74	0.80	0.83	0.029	0.031	0.033
C	0.47		0.65	0.019		0.026
C2	2.45		2.75	0.096		0.108
C3	2.60		3.00	0.102		0.118
D	8.80		9.30	0.346		0.366
E	9.80		10.4	0.386		0.410
F	6.40		6.80	0.252		0.268
G	2.40		2.70	0.094		0.106
H	28.0		29.8	1.102		1.173
L1		3.63			0.143	
L2	1.14		1.70	0.045		0.067
L3		3.30			0.130	
V1		45°			45°	

DELIVERY MODE

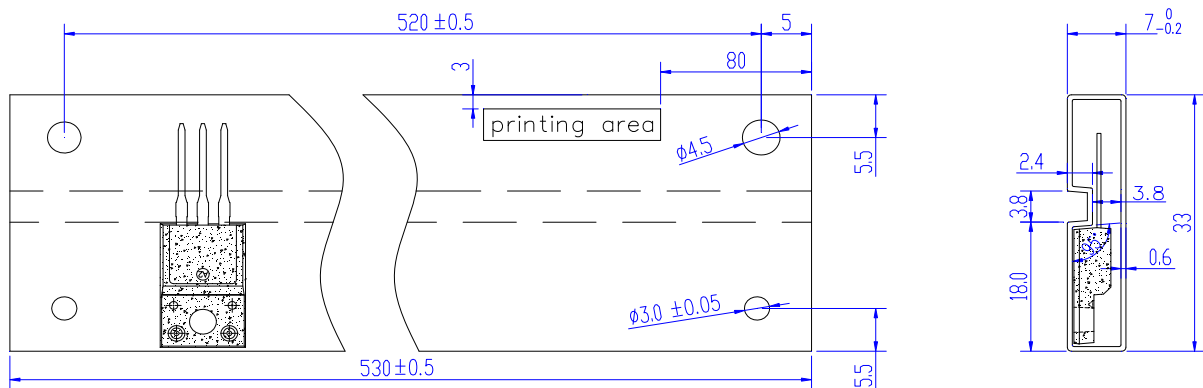

PACKAGE	OUTLINE	TUBE (PCS)	INNER BOX (PCS)	PER CARTON
TO-220F	TUBE	50	1,000	5,000



Information furnished in this document is believed to be accurate and reliable. However, Jiangsu JieJie Microelectronics Co.,Ltd assumes no responsibility for the consequences of use without consideration for such information nor use beyond it. Information mentioned in this document is subject to change without notice, apart from that when an agreement is signed, Jiangsu JieJie complies with the agreement. Products and information provided in this document have no infringement of patents. Jiangsu JieJie assumes no responsibility for any infringement of other rights of third parties which may result from the use of such products and information. This document supersedes and replaces all information previously supplied.

 is a registered trademark of Jiangsu JieJie Microelectronics Co.,Ltd.

Copyright ©2022 Jiangsu JieJie Microelectronics Co.,Ltd. Printed All rights reserved.