



DESCRIPTION:

With low holding and latching current, JST136 series triacs are especially recommended for use on middle and small resistance type power load. From all three terminals to external heatsink, JST136A provides a rated insulation voltage of 2500 V_{RMS}, and JST136F provides a rated insulation voltage of 2000 V_{RMS}, complying with UL standards (File ref: E252906). All the packages Listed above are RoHS compliant. (2011/65/EU)

MAIN FEATURES

Symbol	Value	Unit
I _{T(RMS)}	4	A
V _{DRM} /V _{RPM}	600/800	V

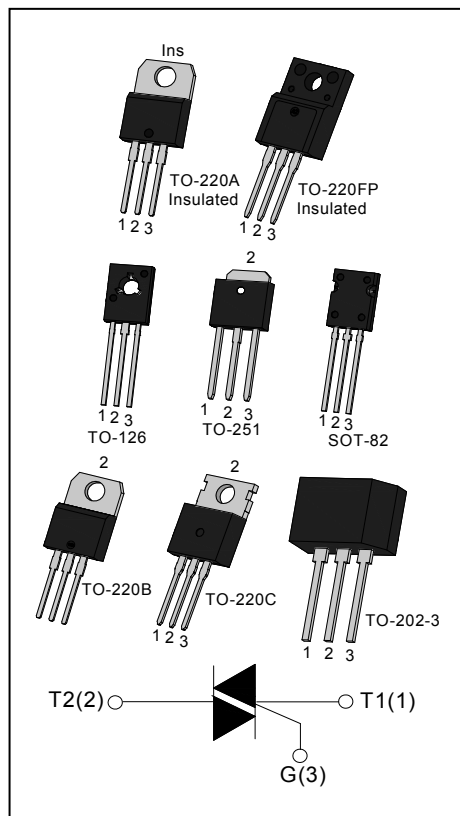

ABSOLUTE MAXIMUM RATINGS

Parameter		Symbol	Value	Unit
Storage junction temperature range		T _{stg}	-40-150	°C
Operating junction temperature range		T _j	-40-125	°C
Repetitive peak off-state voltage(T _j =25°C)		V _{DRM}	600/800	V
Repetitive peak reverse voltage(T _j =25°C)		V _{RPM}	600/800	V
Non repetitive surge peak Off-state voltage		V _{DSM}	V _{DRM} + 100	V
Non repetitive peak reverse voltage		V _{RSM}	V _{RPM} + 100	V
RMS on-state current	TO-251/ TO-220B(Non-Ins) /TO-220C (T _c =105°C)	I _{T(RMS)}	4	A
	TO-220A(Ins)/ TO-220F(Ins) (T _c =100°C)			
	TO-202-3/ TO-126/SOT-82 (T _c =95°C)			

Non repetitive surge peak on-state current (full cycle, F=50Hz)	I_{TSM}	35	A
I^2t value for fusing ($t_p=10ms$)	I^2t	6.1	A^2s
Critical rate of rise of on-state current ($I_G=2 \times I_{GT}$)	I - II - III	50	$A/\mu s$
	IV	10	
Peak gate current	I_{GM}	2	A
Average gate power dissipation	$P_{G(AV)}$	0.5	W
Peak gate power	P_{GM}	5	W

ELECTRICAL CHARACTERISTICS ($T_j=25^\circ C$ unless otherwise specified)

Symbol	Test Condition	Quadrant		Value				Unit
				T	D	E	F	
I_{GT}	$V_D=12V$	I - II - III	MAX	5	5	10	25	mA
		IV		5	10	25	70	
V_{GT}		ALL	MAX	1.3				V
V_{GD}	$V_D=V_{DRM}$ $T_j=125^\circ C$ $R_L=3.3K\Omega$	ALL	MIN	0.2				V
I_L	$I_G=1.2I_{GT}$	I - III	MAX	10	20	30	40	mA
		II - IV		15	35	45	60	
I_H	$I_T=100mA$		MAX	5	15	25	30	mA
dV/dt	$V_D=2/3V_{DRM}$ Gate Open $T_j=125^\circ C$		MIN	20	50	100	150	$V/\mu s$
(dV/dt) _c	(dI/dt) _c =1.7A/ms $T_j=125^\circ C$		MIN	0.1	0.1	0.5	5	$V/\mu s$

STATIC CHARACTERISTICS

Symbol	Parameter		Value(MAX)	Unit
V_{TM}	$I_{TM}=5.5A$ $t_p=380\mu s$	$T_j=25^\circ C$	1.6	V
I_{DRM}	$V_D=V_{DRM}$ $V_R=V_{RRM}$	$T_j=25^\circ C$	5	μA
I_{RRM}		$T_j=125^\circ C$	0.5	mA

THERMAL RESISTANCES

Symbol	Parameter	Value	Unit
R _{th(j-c)}	junction to case(AC)	TO-251	2.8
		TO-220A(Ins)	3.5
		TO-220B(Non-Ins)/ TO-220C	2.5
		TO-220F(Ins)	3.3
		TO-126/SOT-82	3.7
		TO-202-3	3.9

ORDERING INFORMATION

JieJie Microelectronics Co.,Ltd TRIACs I _{T(RMS)} :4A A:TO-220A(Ins) B:TO-220B(Non-Ins) C:TO-220C H:TO-251 Q:TO-126 QP:SOT-82 S3:TO-202-3 F:TO-220F(Ins)	J ST 136 B -600 D	T:I _G T1-3≤5mA I _G T4≤5mA D:I _G T1-3≤5mA I _G T4≤10mA E:I _G T1-3≤10mA I _G T4≤25mA F:I _G T1-3≤25mA I _G T4≤70mA 600:V _{DRM} /V _{RRM} ≥600V 800:V _{DRM} /V _{RRM} ≥800V
--	--	---

PACKAGE MECHANICAL DATA

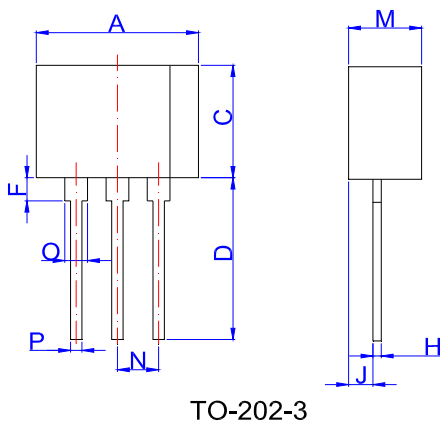

Ref.	Dimensions					
	Millimeters			Inches		
	Min.	Typ.	Max.	Min.	Typ.	Max.
A	9.30		9.90	0.366		0.390
C	7.0		7.6	0.276		0.299
D	10.5		11.5	0.413		0.453
F	1.50		2.50	0.059		0.098
H	0.45		0.55	0.018		0.022
J	1.50		1.90	0.059		0.075
M	4.40		4.70	0.173		0.185
N		2.54			0.100	
O	1.20		1.50	0.047		0.059
P	0.60		0.80	0.024		0.031

PACKAGE MECHANICAL DATA

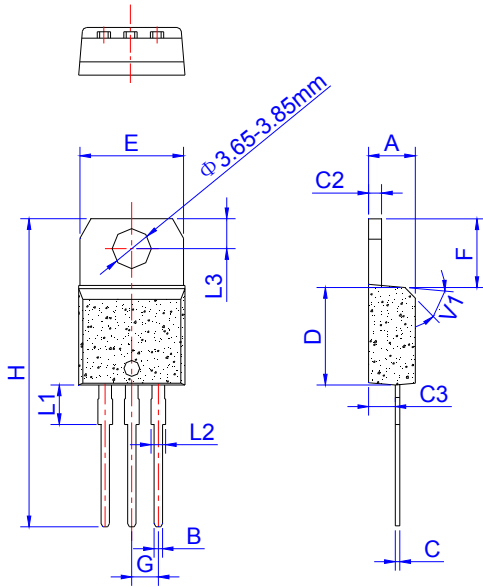

Ref.	Dimensions					
	Millimeters			Inches		
	Min.	Typ.	Max.	Min.	Typ.	Max.
A	4.40		4.60	0.173		0.181
B	0.61		0.88	0.024		0.035
C	0.46		0.70	0.018		0.028
C2	1.21		1.32	0.048		0.052
C3	2.40		2.72	0.094		0.107
D	8.60		9.70	0.339		0.382
E	9.80		10.4	0.386		0.409
F	6.55		6.95	0.258		0.274
G	2.40		2.70	0.094		0.106
H	28.0		29.8	1.102		1.173
L1		3.75			0.148	
L2	1.14		1.70	0.045		0.067
L3	2.65		2.95	0.104		0.116
V1		45°			45°	

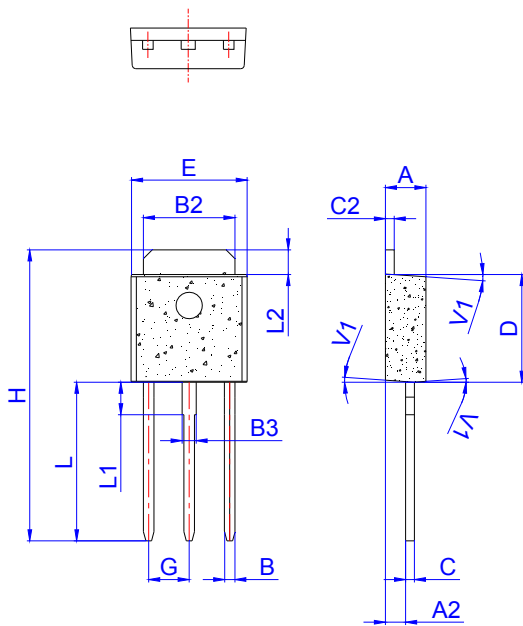

Ref.	Dimensions					
	Millimeters			Inches		
	Min.	Typ.	Max.	Min.	Typ.	Max.
A	2.20		2.40	0.086		0.095
A2	0.90		1.20	0.035		0.047
B	0.55		0.65	0.022		0.026
B2	5.10		5.40	0.200		0.213
B3	0.76		0.85	0.030		0.033
C	0.45		0.62	0.018		0.024
C2	0.48		0.62	0.019		0.024
D	6.00		6.20	0.236		0.244
E	6.40		6.70	0.252		0.264
G		2.30			0.091	
H	16.0		17.0	0.630		0.669
L	8.90		9.40	0.350		0.370
L1	1.80		1.90	0.071		0.075
L2	1.37		1.50	0.054		0.059
V1		4°			4°	

PACKAGE MECHANICAL DATA

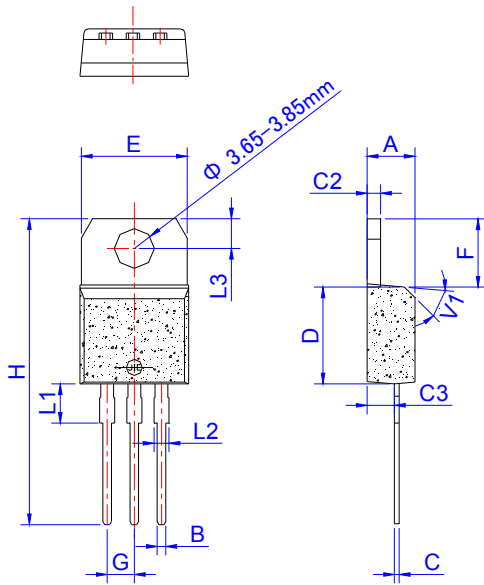

Ref.	Dimensions					
	Millimeters			Inches		
	Min.	Typ.	Max.	Min.	Typ.	Max.
A	4.40		4.60	0.173		0.181
B	0.61		0.88	0.024		0.035
C	0.46		0.70	0.018		0.028
C2	1.21		1.32	0.048		0.052
C3	2.40		2.72	0.094		0.107
D	8.60		9.70	0.339		0.382
E	9.60		10.4	0.378		0.409
F	6.20		6.60	0.244		0.260
G	2.40		2.70	0.094		0.106
H	28.0		29.8	1.102		1.173
L1		3.75			0.147	
L2	1.14		1.70	0.045		0.067
L3	2.65		2.95	0.104		0.116
V1		45°			45°	

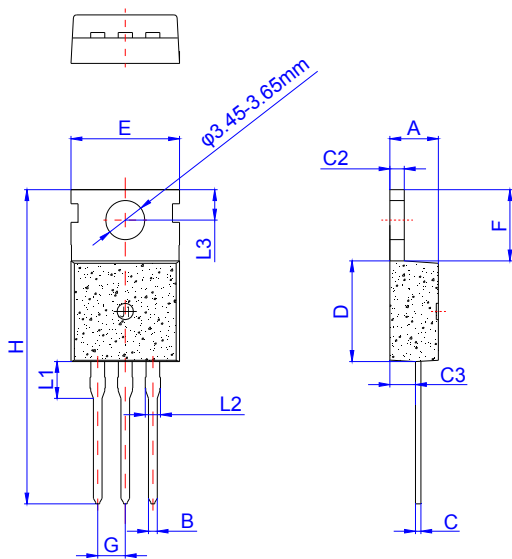

Ref.	Dimensions					
	Millimeters			Inches		
	Min.	Typ.	Max.	Min.	Typ.	Max.
A	4.40		4.60	0.173		0.181
B	0.70		0.90	0.028		0.035
C	0.45		0.60	0.018		0.024
C2	1.23		1.32	0.048		0.052
C3	2.20		2.60	0.087		0.102
D	8.90		9.90	0.350		0.390
E	9.90		10.3	0.390		0.406
F	6.30		6.90	0.248		0.272
G		2.54			0.1	
H	28.0		29.8	1.102		1.173
L1		3.39			0.133	
L2	1.14		1.70	0.045		0.067
L3	2.65		2.95	0.104		0.116

PACKAGE MECHANICAL DATA

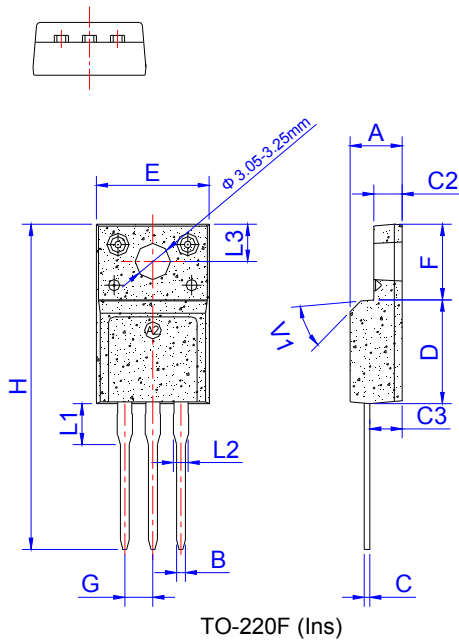

Ref.	Dimensions					
	Millimeters			Inches		
	Min.	Typ.	Max.	Min.	Typ.	Max.
A	4.50		4.90	0.177		0.193
B	0.74	0.80	0.83	0.029	0.031	0.033
C	0.47		0.65	0.019		0.026
C2	2.45		2.75	0.096		0.108
C3	2.60		3.00	0.102		0.118
D	8.80		9.30	0.346		0.366
E	9.80		10.4	0.386		0.410
F	6.40		6.80	0.252		0.268
G	2.40		2.70	0.094		0.106
H	28.0		29.8	1.102		1.173
L1		3.63			0.143	
L2	1.14		1.70	0.045		0.067
L3		3.30			0.130	
V1		45°			45°	

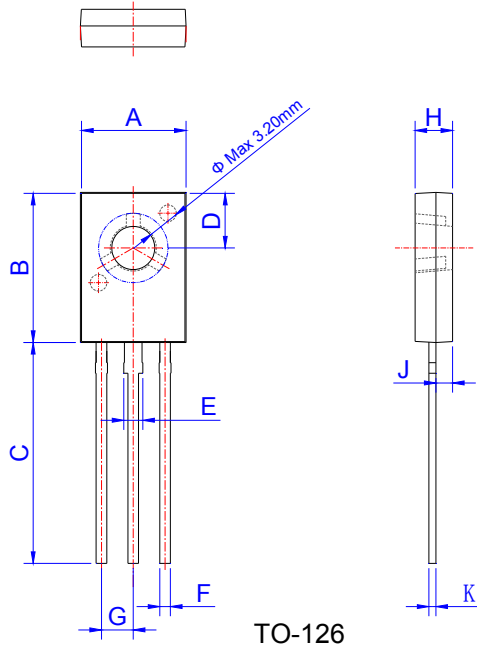

Ref.	Dimensions					
	Millimeters			Inches		
	Min.	Typ.	Max.	Min.	Typ.	Max.
A	7.40		7.80	0.291		0.307
B	10.6		11.2	0.417		0.441
C	15.3		16.3	0.602		0.642
D	3.90		4.10	0.154		0.161
E	1.17		1.47	0.046		0.058
F	0.66		0.86	0.026		0.034
G		2.29			0.090	
H	2.50		2.90	0.098		0.114
J	1.10		1.50	0.043		0.059
K	0.45		0.60	0.018		0.024

PACKAGE MECHANICAL DATA

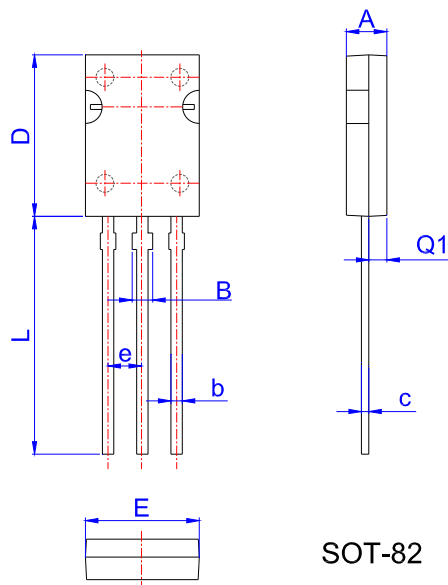

Ref.	Dimensions					
	Millimeters			Inches		
	Min.	Typ.	Max.	Min.	Typ.	Max.
A	2.45	2.55	2.65	0.096	0.100	0.104
b	0.71	0.76	0.81	0.028	0.030	0.032
B	1.27	1.37	1.45	0.050	0.054	0.057
c	0.48	0.50	0.52	0.019	0.020	0.021
D	10.60	10.80	11.00	0.417	0.425	0.433
E	7.30		7.70	0.287		0.303
e	2.24	2.29	2.34	0.088	0.090	0.092
L	15.30	15.60	15.90	0.602	0.614	0.626
Q1	1.17	1.27	1.37	0.046	0.050	0.054

MARKING

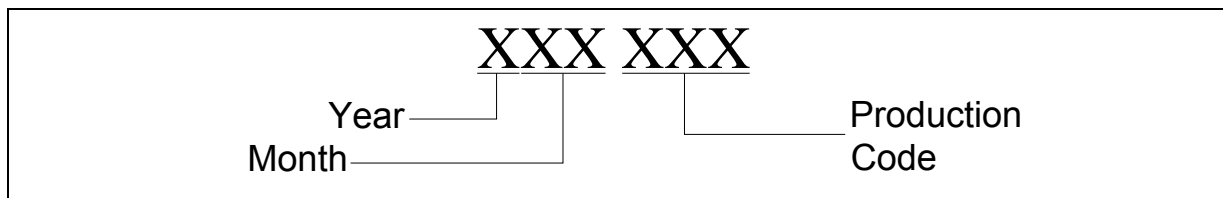
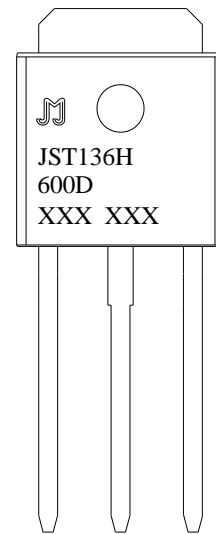
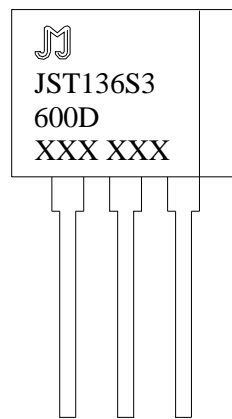
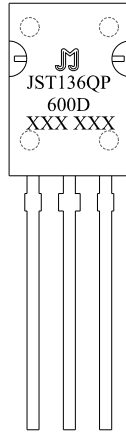
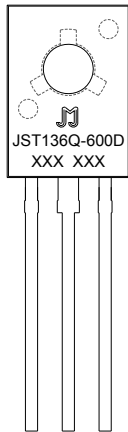
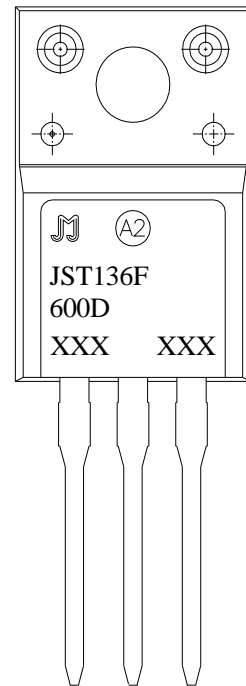
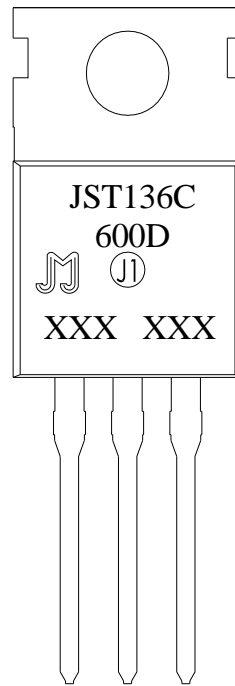
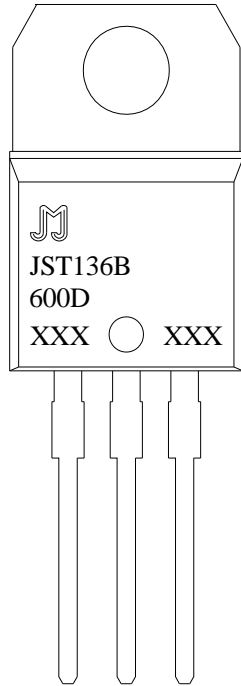
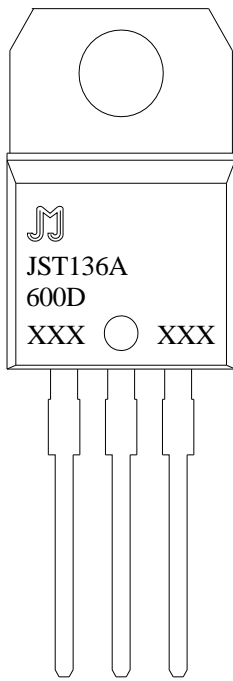

FIG.1: Maximum power dissipation versus RMS on-state current

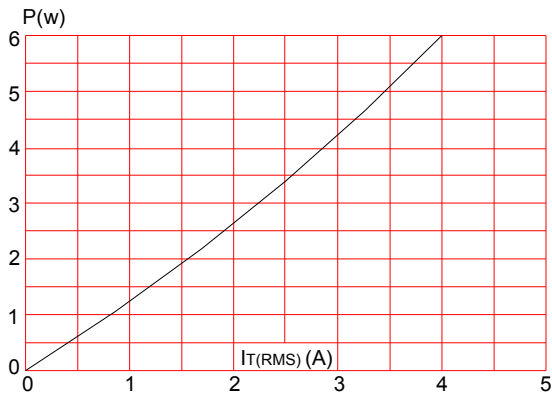

FIG.3: Surge peak on-state current versus number of cycles

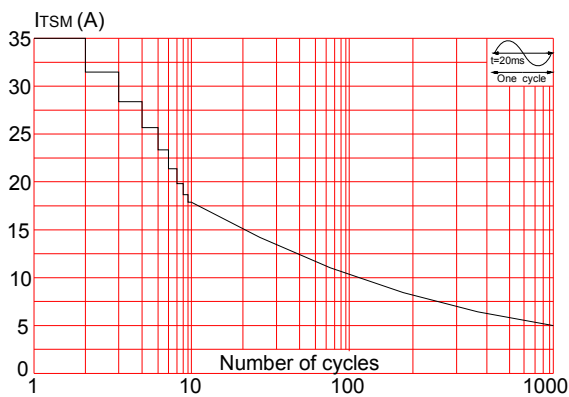

FIG.5: Non-repetitive surge peak on-state current for a sinusoidal pulse with width $t_p < 20\text{ms}$ and corresponding value of I^2t (I - II -III: $dI/dt < 50\text{A}/\mu\text{s}$; IV: $dI/dt < 10\text{A}/\mu\text{s}$)

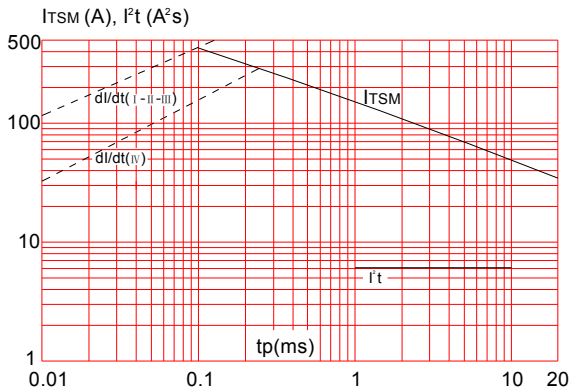

FIG.2: RMS on-state current versus case temperature

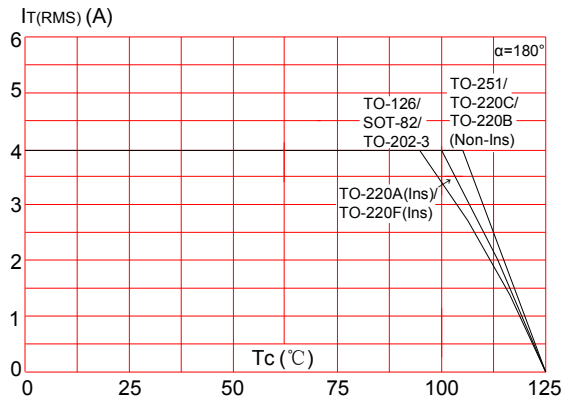

FIG.4: On-state characteristics (maximum values)

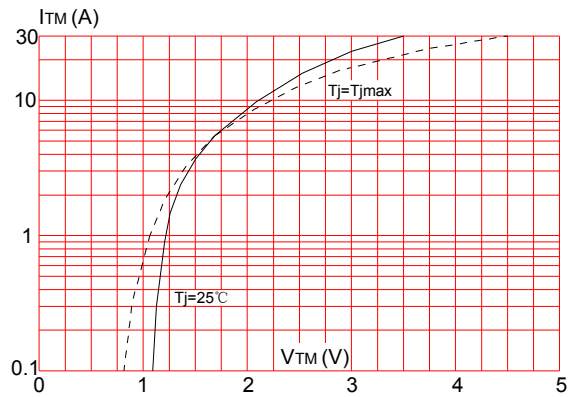

FIG.6: Relative variations of gate trigger current versus junction temperature

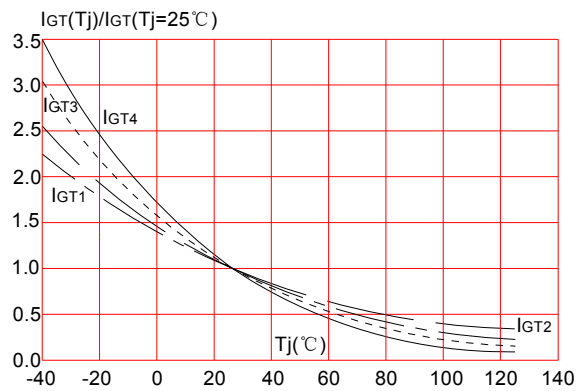

FIG.7: Relative variations of holding current versus junction temperature

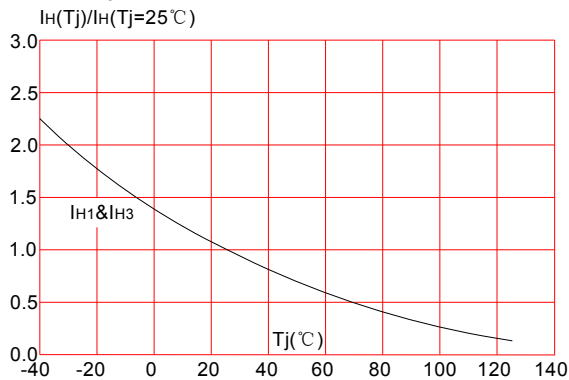
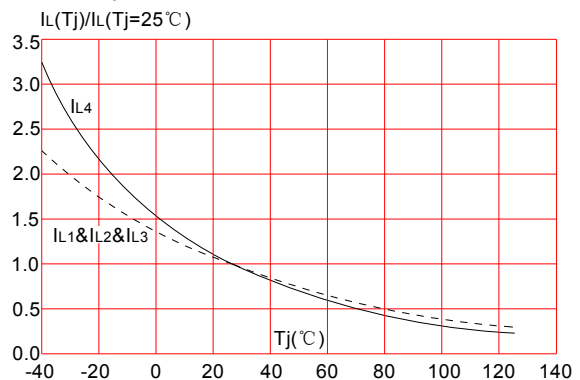



FIG.8: Relative variations of latching current versus junction temperature



Information furnished in this document is believed to be accurate and reliable. However, Jiangsu JieJie Microelectronics Co.,Ltd assumes no responsibility for the consequences of use without consideration for such information nor use beyond it. Information mentioned in this document is subject to change without notice, apart from that when an agreement is signed, Jiangsu JieJie complies with the agreement. Products and information provided in this document have no infringement of patents. Jiangsu JieJie assumes no responsibility for any infringement of other rights of third parties which may result from the use of such products and information. This document is the twelfth version which is made in 23-Feb.-2018. This document supersedes and replaces all information previously supplied.

 is a registered trademark of Jiangsu JieJie Microelectronics Co.,Ltd.

Copyright ©2018 Jiangsu JieJie Microelectronics Co.,Ltd. Printed All rights reserved.