

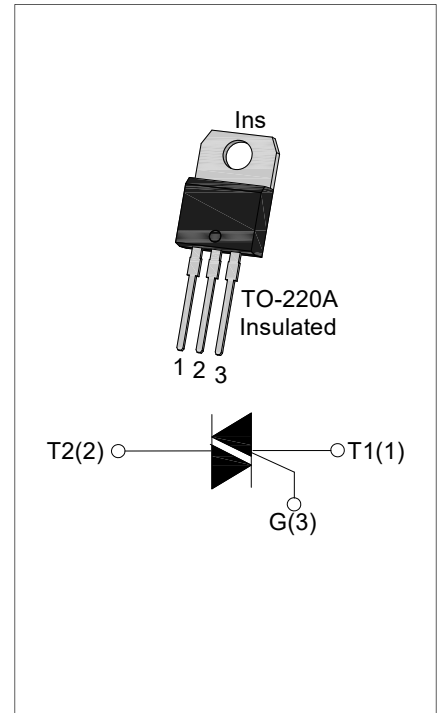

### DESCRIPTION:

With high ability to withstand the shock loading of large current, JST16A-800SW triac provide high dv/dt rate with strong resistance to electromagnetic interface. With high commutation performances, especially recommended for use on inductive load. From all three terminals to external heatsink, JST16A-800SW provides a rated insulation voltage of 2500 V<sub>RMS</sub>, complying with UL standards (File ref: E252906). Package TO-220A is RoHS compliant. (2011/65/EU)



### MAIN FEATURES

Symbol	Value	Unit
$I_{T(RMS)}$	16	A
$V_{DRM}/V_{RRM}$	800	V

### ABSOLUTE MAXIMUM RATINGS

Parameter		Symbol	Value	Unit
Storage junction temperature range		$T_{stg}$	-40-150	°C
Operating junction temperature range		$T_j$	-40-125	°C
Repetitive peak off-state voltage ( $T_j=25^\circ\text{C}$ )		$V_{DRM}$	800	V
Repetitive peak reverse voltage ( $T_j=25^\circ\text{C}$ )		$V_{RRM}$	800	V
Non repetitive surge peak Off-state voltage		$V_{DSM}$	$V_{DRM} + 100$	V
Non repetitive peak reverse voltage		$V_{RSM}$	$V_{RRM} + 100$	V
RMS on-state current	TO-220A(Ins) ( $T_C=90^\circ\text{C}$ )	$I_{T(RMS)}$	16	A
Non repetitive surge peak on-state current (full cycle, F=50Hz)		$I_{TSM}$	160	A
$I^2t$ value for fusing ( $t_p=10\text{ms}$ )		$I^2t$	128	$\text{A}^2\text{s}$
Critical rate of rise of on-state current ( $I_G=2 \times I_{GT}$ )		$di/dt$	50	$\text{A}/\mu\text{s}$
Peak gate current $t_p=20\mu\text{s}$		$I_{GM}$	4	A
Average gate power dissipation		$P_{G(AV)}$	1	W
Peak gate power $t_p=20\mu\text{s}$		$P_{GM}$	5	W

**ELECTRICAL CHARACTERISTICS** ( $T_j=25^{\circ}\text{C}$  unless otherwise specified)

Symbol	Test Condition	Quadrant		Value	Unit
$I_{GT}$	$V_D = 12\text{V}$ $R_L = 33\Omega$	I - II - III	MAX	10	mA
$V_{GT}$		I - II - III	MAX	1.3	V
$V_{GD}$	$V_D = V_{DRM}$ $T_j = 125^{\circ}\text{C}$ $R_L = 3.3\text{K}\Omega$	I - II - III	MIN	0.2	V
$I_L$	$I_G = 1.2I_{GT}$	I - III	MAX	30	mA
		II		40	
$I_H$	$I_T = 100\text{mA}$		MAX	25	mA
dv/dt	$V_D = 2/3V_{DRM}$ Gate Open $T_j = 125^{\circ}\text{C}$		MIN	200	V/ $\mu\text{s}$

**STATIC CHARACTERISTICS**

Symbol	Parameter		Value(MAX)	Unit
$V_{TM}$	$I_{TM} = 22.5\text{A}$ $t_p = 380\mu\text{s}$	$T_j = 25^{\circ}\text{C}$	1.5	V
$V_{TO}$	Threshold voltage	$T_j = 125^{\circ}\text{C}$	0.93	V
$R_d$	Dynamic resistance	$T_j = 125^{\circ}\text{C}$	26	m $\Omega$
$I_{DRM}$	$V_D = V_{DRM}$ $V_R = V_{RRM}$	$T_j = 25^{\circ}\text{C}$	5	$\mu\text{A}$
$I_{RRM}$		$T_j = 125^{\circ}\text{C}$	1	mA

**THERMAL RESISTANCES**

Symbol	Parameter		Value	Unit
$R_{th(j-c)}$	junction to case(AC)	TO-220A(Ins)	1.7	$^{\circ}\text{C}/\text{W}$

ORDERING INFORMATION

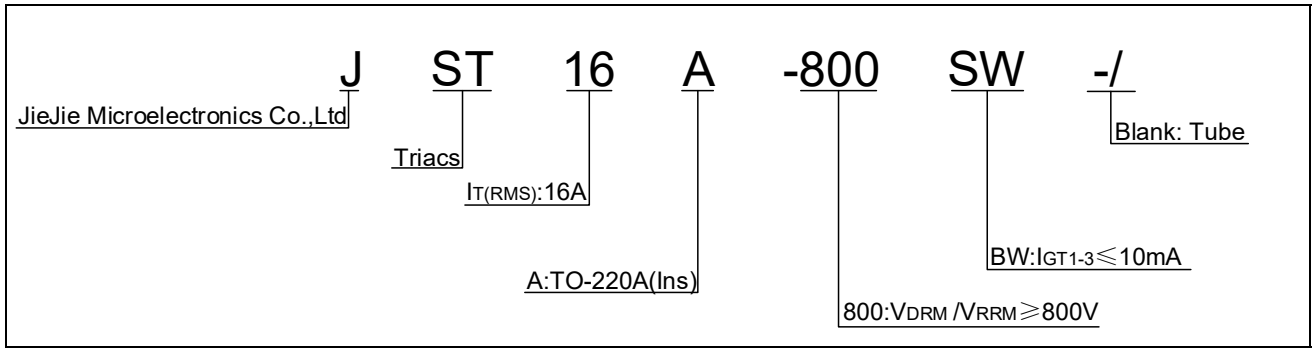

MARKING

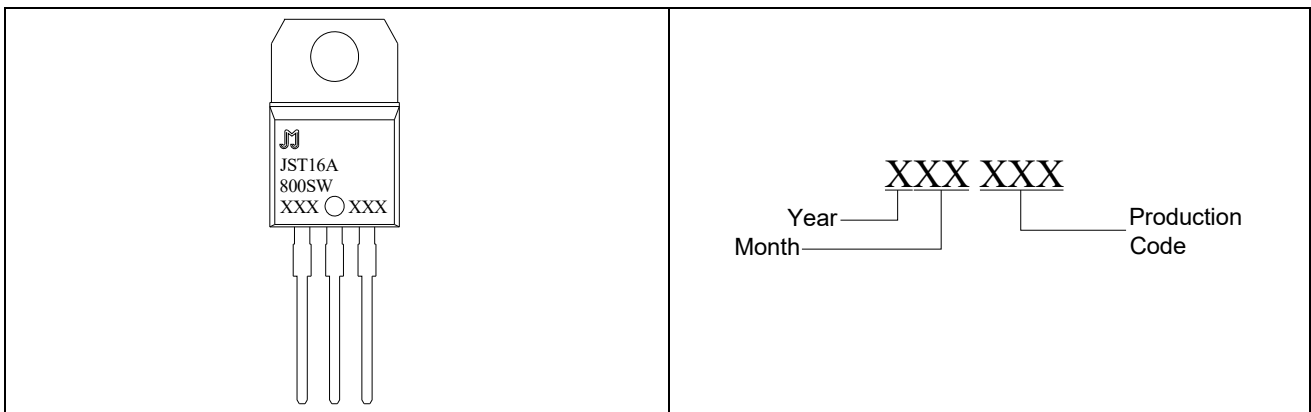

**FIG.1:** Maximum power dissipation versus RMS on-state current

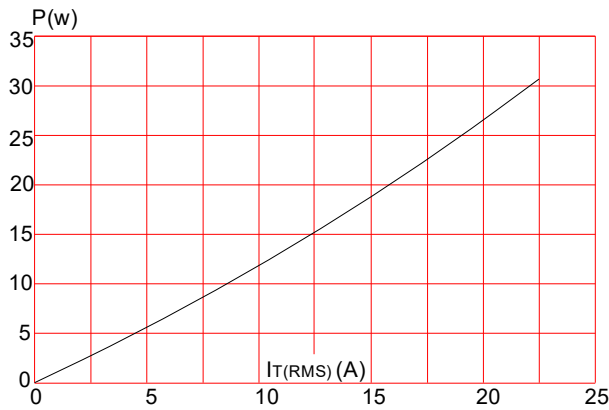

**FIG.3:** Surge peak on-state current versus number of cycles

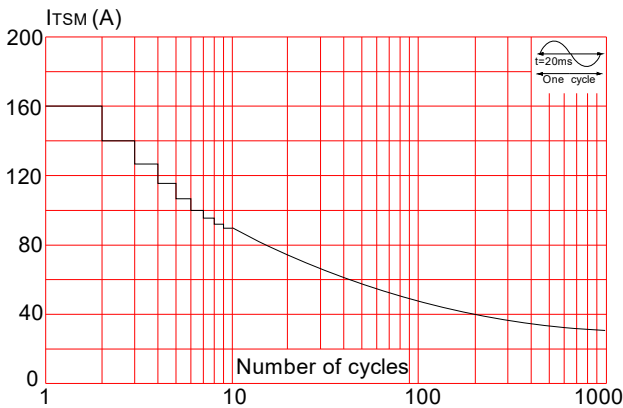

**FIG.5:** Non-repetitive surge peak on-state current for a sinusoidal pulse with width  $t_p < 20\text{ms}$ , and corresponding value of  $I^2t$  ( $di/dt < 50\text{A}/\mu\text{s}$ )

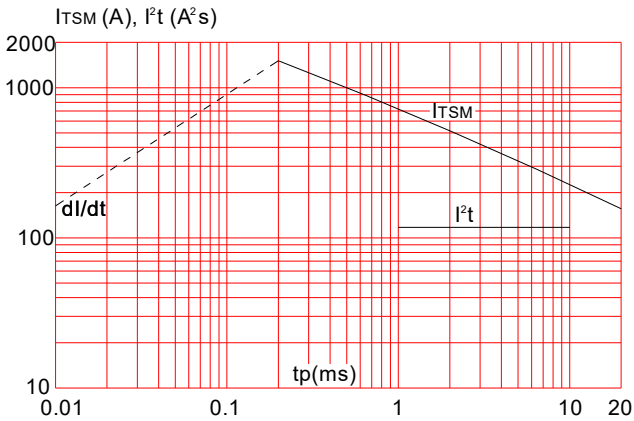

**FIG.2:** RMS on-state current versus case temperature

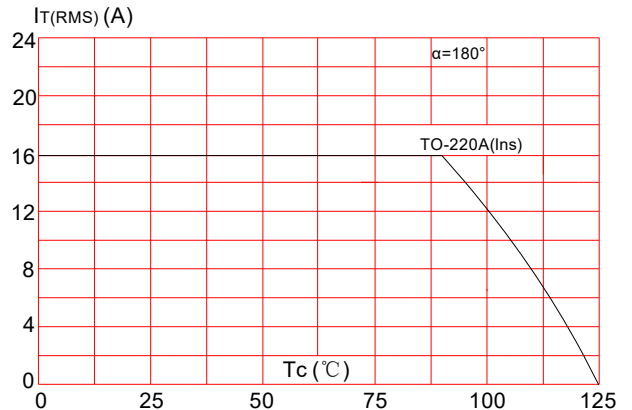

**FIG.4:** On-state characteristics (maximum values)

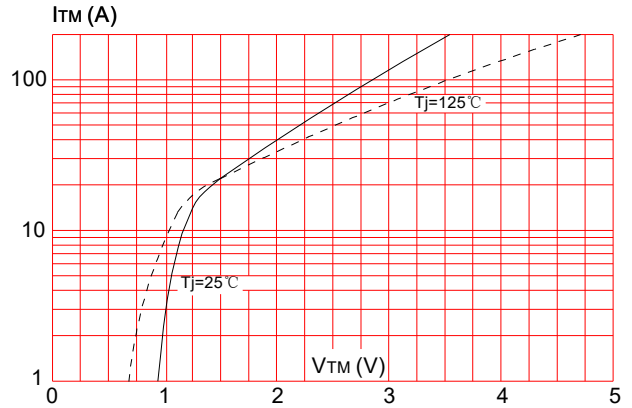

**FIG.6:** Relative variations of gate trigger current, holding current and latching current versus junction temperature

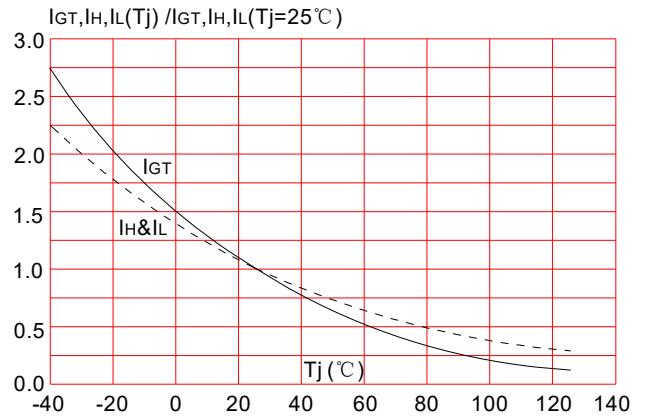

**ORDERING INFORMATION**

Order code	Voltage $V_{DRM}/V_{RRM}$ (V)	IGT(mA)	Package	Base qty. (pcs)	Delivery mode
JST16A-800SW	800	10	TO-220A(Ins)	50	Tube

**Document Revision History**

Date	Revision	Changes
Mar 27, 2022	1	Last update

PACKAGE MECHANICAL DATA

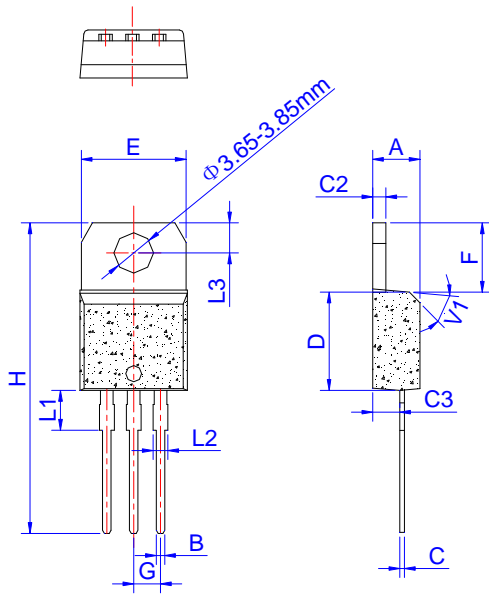

Ref.	Dimensions					
	Millimeters			Inches		
	Min.	Typ.	Max.	Min.	Typ.	Max.
A	4.40		4.60	0.173		0.181
B	0.61		0.88	0.024		0.035
C	0.46		0.70	0.018		0.028
C2	1.21		1.32	0.048		0.052
C3	2.40		2.72	0.094		0.107
D	8.60		9.70	0.339		0.382
E	9.80		10.4	0.386		0.409
F	6.55		6.95	0.258		0.274
G	2.40		2.70	0.094		0.106
H	28.0		29.8	1.102		1.173
L1		3.75			0.148	
L2	1.14		1.70	0.045		0.067
L3	2.65		2.95	0.104		0.116
V1		45°			45°	

DELIVERY MODE

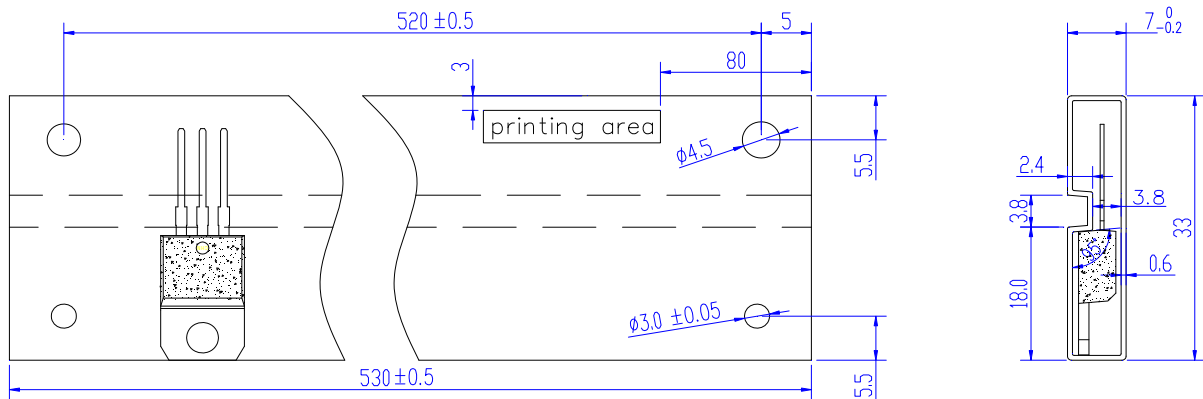

PACKAGE	OUTLINE	TUBE (PCS)	INNER BOX (PCS)	PER CARTON
TO-220A	TUBE	50	1,000	5,000



Information furnished in this document is believed to be accurate and reliable. However, Jiangsu JieJie Microelectronics Co.,Ltd assumes no responsibility for the consequences of use without consideration for such information nor use beyond it. Information mentioned in this document is subject to change without notice, apart from that when an agreement is signed, Jiangsu JieJie complies with the agreement. Products and information provided in this document have no infringement of patents. Jiangsu JieJie assumes no responsibility for any infringement of other rights of third parties which may result from the use of such products and information. This document supersedes and replaces all information previously supplied.



is a registered trademark of Jiangsu JieJie Microelectronics Co.,Ltd.  
Copyright ©2022 Jiangsu JieJie Microelectronics Co.,Ltd. Printed All rights reserved.